



**INFORMATION FOR FIRST RESPONDERS**

**FIRST RESPONDER INTERACTION PLAN**

**TESLA ROBOTAXI**

**AUTONOMOUS VEHICLE SERVICE**



# CONTENTS

1. Contact us	Page 1
2. Identification / recognition	Page 3
3. Autonomous activity	Page 5
4. Autonomous response to incidents	Page 7
5. Operational design domain	Page 9
6. First responder interactions	Page 10
7. Immobilization	Page 11
8. Disable direct hazards / safety regulations	Page 12
9. Access to the occupants	Page 15
10. Towing / transportation / storage	Page 18
11. Important additional information	Page 21

## 1. Contact us

### Tesla Robotaxi Support

In the event of an incident involving a Tesla Robotaxi vehicle, emergency responders can contact Tesla Robotaxi Support 24 hours, toll free, through these methods:

- [Tesla Robotaxi First Responder Support at \(512\) 276-5391](tel:5122765391)
- Tesla Roadside Assistance at (877) 798-3752
- Through the on-board two-way communication device

A Tesla Support Specialist can then assist with your request.

To ensure prompt incident assistance, prepare the following details when you reach out to Tesla Robotaxi Support:

- Your name.
- Your agency.
- Your badge number or identification number.
- The VIN or license plate of any Tesla Robotaxi vehicles involved.
- The location of the incident.

The most current version of the Robotaxi First Responder Interaction Plan and the Emergency Response Guides of Robotaxi vehicles can be found at <https://www.tesla.com/firstresponders>. **Always consult the most current version of the First Responder Interaction Plan, as some first responder interactions can change.**

If you are a first responder and would like to request more information about Robotaxi or this document, contact Tesla at [RobotaxiFirstResponderSafety@tesla.com](mailto:RobotaxiFirstResponderSafety@tesla.com) and request to speak with a Tesla Robotaxi First Responder Liaison. This email is not monitored for emergency requests. Contact Tesla Robotaxi Support through Tesla Roadside Assistance to geofence Robotaxi or make an emergency request to Robotaxi Operations.

### Geofencing

To redirect or geofence autonomous vehicle traffic due to road closure, construction, roadway maintenance, or emergency response, call Tesla Robotaxi First Responder Support and provide:

- Your name.
- Your agency.
- Your badge number or identification number.
- Longitude and latitude of the closure.
- Reason for closure.
- Length of time for the closure (if known).
- Your phone number.

Tesla then establishes a temporary geofence that blocks off Robotaxi service within 1000 feet of the location for approximately 1 hour, unless a duration is specified by the requester. You can also request an extension until further notice is given.

## Vehicle Data

Tesla provides vehicle data from accidents and incidents in response to requests from law enforcement. Such requests must be provided with the appropriate legal documentation, such as search warrants and subpoenas. For further instructions, see <https://ts.la/ler-guidelines>.

Data that can be retrieved from a vehicle for first responders may contain:

- Camera recordings.
- Diagnostic logs.
- Data collected by the event data recorder (see <https://edr.tesla.com/>).

For further details on the data that Robotaxi collects, see <https://www.tesla.com/legal/privacy/robotaxi>.

## Vehicle Registration and Insurance

A physical copy of the vehicle registration, vehicle owner information, and proof of insurance is located in the glovebox of each Model Y Robotaxi. To access this information, contact Tesla Robotaxi Support by phone or the on-board two-way communication system.

## First Responder QR Code

The First Responder Interaction Plan is also accessible from a QR code in the bottom left corner of the windshield and can be scanned from outside the vehicle.



## 2. Identification / recognition

### Identifying the vehicle

A Robotaxi vehicle is a Tesla Model Y. A dedicated Tesla Robotaxi can be identified by the Robotaxi label written in gold lettering. Robotaxi labels will be included on the front and rear fascia of the vehicle and may appear at the bottom of the front doors. The Model Y variant used for Robotaxi features more angular front and rear fascias and an additional camera in the front grille.

When the vehicle is operating in Autonomous Mode, there will not be a person in the driver's seat.



A large, stylized black graphic of the word 'ROBOTAXI' is shown. The letters are thick and have a hand-drawn, graffiti-like appearance with some drips at the bottom of the strokes. The word is written in all caps.

## Front and Rear Lights

You can identify the Model Y variant used for Robotaxi from the front and rear by the shape of the headlights and light bar and the TESLA wordmark on the rear.

Consult the appropriate Emergency Response Guide for additional details on identifying the vehicle at <https://www.tesla.com/firstresponders>.



## Vehicle Identification Number (VIN)

The VIN of a Tesla vehicle can be located on the stamped plate on top of the dashboard by looking through the "driver's" side of the windshield.

If the front touchscreen is operational, you can check the VIN by navigating to **Controls > Software**.

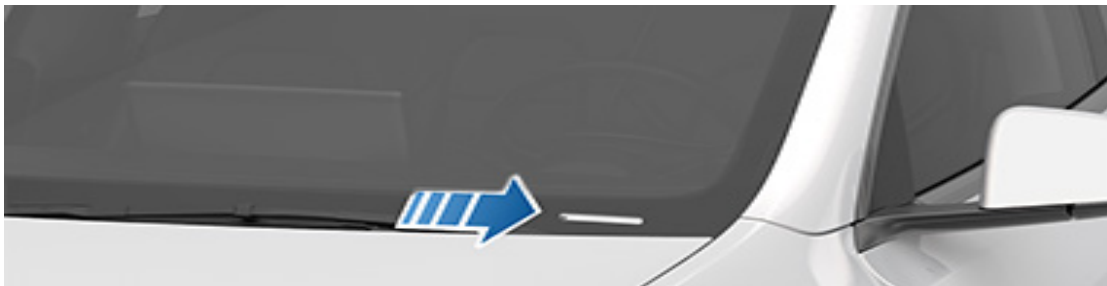

The VIN can also be found on the Vehicle Certification label on the "driver's" side door pillar.



After a safety critical event, low voltage power may not be available and the touchscreen may not be operational. Trying to support low voltage power on a vehicle that has been in a collision could lead to a possible electrical fire. Tesla does not recommend attempting to reconnect low voltage power after an accident.

### 3. Autonomous activity

#### Autonomous Mode



**WARNING** LACK OF MOVEMENT OR VISUAL INDICATION OF AUTONOMOUS MODE DOES NOT MEAN AUTONOMOUS MODE IS OFF. UNTIL THE VEHICLE IS FULLY SHUT OFF AND A TESLA REPRESENTATIVE GIVES THE ALL CLEAR, APPROACH CAUTIOUSLY.

Robotaxi is equipped with Tesla's SAE Level 4 automated driving system. When in Autonomous Mode, the vehicle is designed to be capable of performing the entire dynamic driving task without any input from a human driver.

Robotaxi operates in Autonomous Mode while performing a trip, moving to initiate a trip, going to a parking lot, or proceeding to a charging or cleaning station. A Robotaxi should always be considered in Autonomous Mode unless the hazard lights are flashing rapidly. A Robotaxi operating in Autonomous Mode moves independently and is fully self-driving.

When Robotaxi operates in Autonomous Mode, the words SELF-DRIVING displays in blue in the top left corner of the front vehicle touchscreen. If Autonomous Mode is disabled or currently disengaged, the words SELF-DRIVING do not appear.

65 MPH P R N D Self-Driving

Beyond the capabilities necessary for dynamic driving tasks, Robotaxi exhibits these notable behaviors:

- When picking up passengers, the vehicle shifts to Park. Then, the front and rear lightbars pulse and the hazard lights flash at a normal rate until the vehicle shifts into Drive or Reverse.
- When dropping off passengers, the vehicle shifts to Park. Then, the hazard lights flash at a normal rate until the vehicle shifts into Drive or Reverse.
- Robotaxi is designed to continue autonomous operation after the passengers have exited the vehicle, closed the doors, and retrieved any luggage.
- While waiting for a new ride booking, Robotaxi proceeds to a charging station or parking lot.
- If the Battery charge level is too low to conduct another ride, Robotaxi proceeds to a charging station before accepting new ride bookings.
- If Robotaxi experiences connectivity or hardware issues, the hazard lights flash rapidly and the vehicle attempts to pull over at the nearest safe stopping location.

Robotaxi is also designed to respond to clearly visible hand signals from first responders and can follow pathways designated by cones.

## Disabling Autonomous Mode

Autonomous Mode remains active while the vehicle is parked or idle and is only disabled in these ways:

- By a Tesla representative.
- After a safety critical event is detected, such as a collision or the deployment of airbags.
- After being pulled over by a first responder.
- While charging.

When Autonomous Mode is engaged, vehicle hazard lights flash at the standard rate for pick up and drop off. When Autonomous Mode is disabled, the vehicle hazard lights flash rapidly. Rapid flashing of the hazard lights is at approximately two times the speed of standard hazard light flashing. If the vehicle is being manually driven and no safety critical event has been triggered, Autonomous Mode is disengaged and the hazard lights flash at the standard rate, if activated by the driver.

After Autonomous Mode is disabled, it cannot be re-enabled until a Tesla representative reviews the incident and explicitly initiates Autonomous Mode. If a safety critical event is detected, the doors unlock for easier egress, two-way communication is initiated with the vehicle and a Tesla representative, and the vehicle windows are automatically rolled down if airbags deploy.

You can confirm that Autonomous Mode is disabled by checking the top left corner of the front vehicle touchscreen. Ensure that the blue SELF-DRIVING text is not present.

You can also visually confirm that two-way communication is active by checking the top right corner of the front or rear touchscreen of Robotaxi. When the microphone is active, an orange indicator appears. When the cabin camera is active, a green indicator appears. The rear touchscreen also indicates that Robotaxi Support is connected.

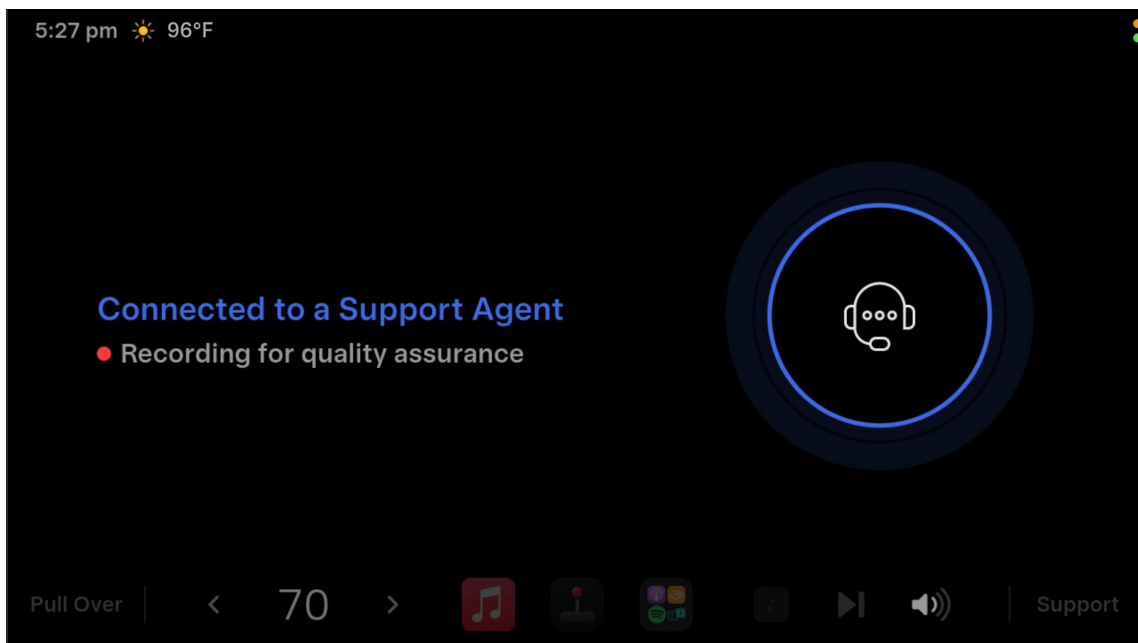

## 4. Autonomous response to incidents and first responders

### Yielding

The Model Y Robotaxi is equipped with a camera suite and sound detection technology. Robotaxi is designed to use this functionality to detect the flashing lights or sirens of approaching emergency vehicles. Upon detecting a nearby first responder vehicle, Robotaxi attempts to slow and yield or pull over to the nearest safe stopping location available to permit emergency vehicles to proceed.



**NOTE** The hazard lights do not flash rapidly if Robotaxi is only yielding for first responders.

### Stops

Robotaxi is designed to detect when a first responder vehicle is following Robotaxi with lights and sirens on. When Robotaxi detects that a first responder vehicle is following with lights and sirens active, Robotaxi pulls over and parks at the first safe location available. When pulling over, Robotaxi attempts to avoid entering or blocking private driveways. If on the highway, after moving to the rightmost traffic lane, Robotaxi might take some time to identify a safe location to pull over and stop. After pulling over and parking, Autonomous Mode disengages and Robotaxi rapidly flashes the hazard lights for the duration of the stop to indicate that the vehicle is now parked and safe to approach. Robotaxi then remains stationary until a Tesla representative remotely moves the vehicle or re-engages Autonomous Mode.

When a stop begins, Robotaxi rolls down both the front windows and initiates two-way communication between the vehicle cabin and Tesla Robotaxi Support. First responders can then speak directly to the Tesla representative using the on-board two-way speaker.

Before approaching the vehicle, Tesla recommends you contact Tesla Robotaxi Support to ensure that Autonomous Mode is disabled and that the vehicle is safely immobilized. The Tesla representative can then remotely unlock the doors or trunks, open the glove box, or roll down additional windows, as needed.

You can visually confirm that Autonomous Mode is disabled by checking for the top left corner of the front touchscreen for SELF-DRIVING in blue text. Ensure that SELF-DRIVING is **not** present.

If the vehicle is unoccupied, the front and rear passenger doors automatically unlock when Autonomous Mode disengages. If the on-board two-way communication with Tesla Robotaxi Support fails to initiate or cannot stay connected, call Tesla Roadside Assistance.

First responders can also manually initiate two-way communication with Tesla Robotaxi Support by touching the Support icon on the front or rear touchscreen. The vehicle then initiates two-way communication.

First responders should communicate completion of a stop to the Tesla representative upon conclusion of activities, so that Robotaxi can resume autonomous operations.

## Collisions and Safety Critical Events

Robotaxi is designed to detect the occurrence of a safety critical event (such as a collision or airbag deployment). When detected, the vehicle is designed to stop, park, and disable Autonomous Mode where possible. Robotaxi flashes the hazard lights rapidly, unlocks the doors for easier egress, rolls down all of the windows to vent the cabin if airbags deploy, and initiates two-way communication between the vehicle cabin and Tesla Robotaxi Support. Tesla Robotaxi Support can then contact 911 if necessary. The vehicle is designed to remain stationary until the Robotaxi Field Response Team and/or first responders have completed their on-scene investigation of the incident. A Tesla Representative may respond to the scene of a collision to assist first responders if necessary.

Autonomous Mode is typically disabled in a safety critical event if you see the following:

- Flashing hazard lights.
- Deployed airbags.

## Moving the Vehicle

If the vehicle is in the roadway or in a dangerous position and two-way communication with Tesla Robotaxi Support is successful, request that the Tesla representative move the vehicle remotely.

If the Tesla representative cannot move the vehicle, request vehicle control access. First responders requesting vehicle control access must be in uniform and must be ready to present their badge or official identification to the camera on the vehicle B-pillar. A Tesla representative can then verify the first responder's identity and grant access to the vehicle controls. For details on driving a Tesla vehicle, see "Driving the Vehicle" in Chapter 11, Towing / transportation / storage on page 19.

If the vehicle cannot be moved by the Tesla representative or by first responders with vehicle control access, first responders can proceed with standard stabilization, lifting, and towing procedures to clear the roadway. Consult the appropriate Emergency Response Guide at <https://www.tesla.com/firstresponders> for details around stabilization and lifting.



**WARNING** The vehicle is designed to cut high voltage power if airbags deploy. In such cases, you must enable Tow Mode before you can safely move or push the vehicle. If you cannot enable Tow Mode, do not move the vehicle with wheels on the ground and do not allow the wheels to spin.

## Vehicle Behavior When a Collision or Stop Occurs

The vehicle is designed to perform the following when it detects a stop by first responders or a safety critical event that disengages Autonomous Mode:

1. Automatically save camera recordings before and after the event.
2. Log an incident with Tesla Robotaxi Support.
  - A. Disengagements of Autonomous Mode are also classified as incidents.
3. Flash hazard lights rapidly.
4. Doors unlock.
  - A. If a safety critical event was detected, unlocks all the doors for easier egress.
  - B. If a stop by first responders was detected and the vehicle is unoccupied, unlocks the passenger doors.
5. Roll down the windows.
  - A. All windows are fully rolled down in the event of a safety critical event where airbags deploy.
  - B. Only the front windows are rolled down for a traffic stop.
6. Initiate two-way communication between the vehicle cabin and a Tesla Representative.

## 5. Operational design domain and service operations

### Operational Design Domain

The Robotaxi operational design domain includes all public roadways, such as freeways, highways, city streets, and rural roads, as well as private roadways and service stations, such as parking lots, charging stations, car washes, and parking garages. Robotaxi is also capable of navigating pick-up and drop-off zones to initiate or complete trips.

Robotaxi can operate autonomously at all times of day and night, and under light and moderate precipitation such as rain, fog, and snow. Consistent with its operational design domain, Robotaxi vehicles are designed to safely adjust their speed to the flow of traffic.

Robotaxi has limited operational capability under extreme weather conditions, such as flooding, heavy rain, snowy or icy roads, and hurricane-strength winds, and is not intended for use in such situations at this time. Robotaxi is also not designed to operate off-road.

Autonomous vehicles under the operational control of Tesla can follow guidance issued through public safety alerts for inclement weather expected to impact road safety. Affected autonomous vehicles can either avoid the affected roadways or can be ordered to return to the closest charging station or parking lot.

Robotaxi does not accept new rides when extreme weather conditions are expected. If unexpectedly caught by extreme weather conditions, Robotaxi is designed to pull over at the nearest safe stopping location and park. Tesla Robotaxi Support is then notified and can recover the vehicle and/or passengers.

### Robotaxi Mission Control

Robotaxi is an autonomous ride-hailing taxi service that enables customers to book rides. All Robotaxi vehicles are owned and operated by Tesla at this time. Robotaxi Mission Control coordinates and manages rides on Robotaxi vehicles, and handles any charging and maintenance.

In the event of a severe incident, Robotaxi Mission Control may dispatch Robotaxi support personnel to assist with first responder interactions.

For the hours of operation for Robotaxi service, see <https://www.tesla.com/support/robotaxi/getting-started#hours>.

For the Arizona Areas of Operation Appendix, see <https://www.tesla.com/firstresponders/robotaxi>.

## 6. First responder interactions

### Performing a Stop

To perform a stop on a Robotaxi vehicle as a first responder:

1. Pull up behind the Robotaxi vehicle.
2. Turn on your sirens and emergency vehicle lights.
3. Stay behind the Robotaxi vehicle as Robotaxi pulls over and parks. Wait for the vehicle to rapidly flash hazard lights, signifying that Autonomous Mode is disengaged.
4. Establish communications with Tesla Robotaxi Support.
  - A. Call Tesla Roadside Assistance at 877 798 3752 and request Tesla Robotaxi Support.
  - B. Approach the front "driver" or passenger side window of the vehicle and speak directly via the on-board two-way communication system.
  - C. If the on-board communication system is not connected, touch Support on the front or rear touchscreen to manually initiate two-way communications.
5. (If possible) Confirm that SELF-DRIVING does not appear in the top left corner of the front touchscreen.
6. Immobilize the vehicle. See Chapter 7, Immobilization on page 10.
7. (If needed) Move the vehicle. Immobilize the vehicle again after moving.

### Responding to an Incident

When responding to an incident or safety critical event involving a Tesla Robotaxi, such as a collision:

1. Pull up behind the Robotaxi vehicle.
2. Turn on your emergency vehicle lights. Ensure that you see Robotaxi rapidly flash hazard lights, signifying that Autonomous Mode is disengaged.
3. Establish communications with Tesla Robotaxi Support.
  - A. Call Tesla Roadside Assistance at 877 798 3752 and request Tesla Robotaxi Support.
  - B. Approach the front "driver" or passenger side window of the vehicle and speak directly via the on-board two-way communication system.
  - C. If the on-board communication system is not connected, touch Support on the front or rear touchscreen to manually initiate two-way communications.
4. (If possible) Confirm that SELF-DRIVING does not appear in the top left corner of the front touchscreen.
5. Immobilize the vehicle. See Chapter 7, Immobilization on page 10.
6. (If needed) Cut the First Responder Loop to disable the vehicle. See Chapter 8, Disable direct hazards on page 11.
7. (If needed) Move the vehicle. Immobilize the vehicle again after moving.

### Completing a Stop or Incident

To complete a stop or response to a Robotaxi vehicle:

1. Remove anything used to immobilize the vehicle.
2. Communicate completion of first responder activities to Tesla Robotaxi Support.
3. (If needed) Request additional assistance, such as towing and cleanup services.

## 7. Immobilization

Consult the appropriate Emergency Response Guide at <https://www.tesla.com/firstresponders> for more details around immobilizing the vehicle.

### IMMOBILIZATION

#### 1. Request vehicle immobilization

Contact Tesla Robotaxi Support and request immobilization of the vehicle. If the windows are rolled down and two-way communication is active, you can speak directly through the two-way speakers in the vehicle.

#### 2. Cage the vehicle

Cage the vehicle in front, behind, and to the sides. The cage must be visible to the vehicle cameras. If you cannot reach Tesla Robotaxi Support, cage the vehicle first before attempting to interact directly with the vehicle.

#### 3. Chock wheels

Robotaxi moves quietly, so never assume it is powered off. Never assume that Robotaxi will not move. Always chock the wheels.



#### 4. Disable movement with the vehicle

You can disable further movement of the vehicle by performing a disengagement method. Robotaxi is designed to disengage Autonomous Mode and park when:

- A seat belt becomes unbuckled (if there's a passenger).
- A cabin door opens and remains open.

Tesla recommends that you block the cabin door from closing or keep the door open after you disable movement of the vehicle to keep the vehicle from re-engaging Autonomous Mode.



**WARNING** Wait for a Tesla representative to confirm that Autonomous Mode has been disabled before attempting significant interaction with the vehicle.



**NOTE** Cut the First Responder Loop if necessary to completely disable the vehicle.

## 8. Disable direct hazards

Consult the appropriate Emergency Response Guide at <https://www.tesla.com/firstresponders> for more details around disabling the vehicle.

### ACCESS

1. Open the hood.
  - A. If there is no low voltage power in the vehicle, see "Opening the Hood using an External Low Voltage Power Supply" in Chapter 8, Disable direct hazards on page 13.
2. Remove any access panels or seals obscuring the first responder loop.

### MAIN DISABLING METHOD

1. Double cut the first responder loop and then remove the cut section.

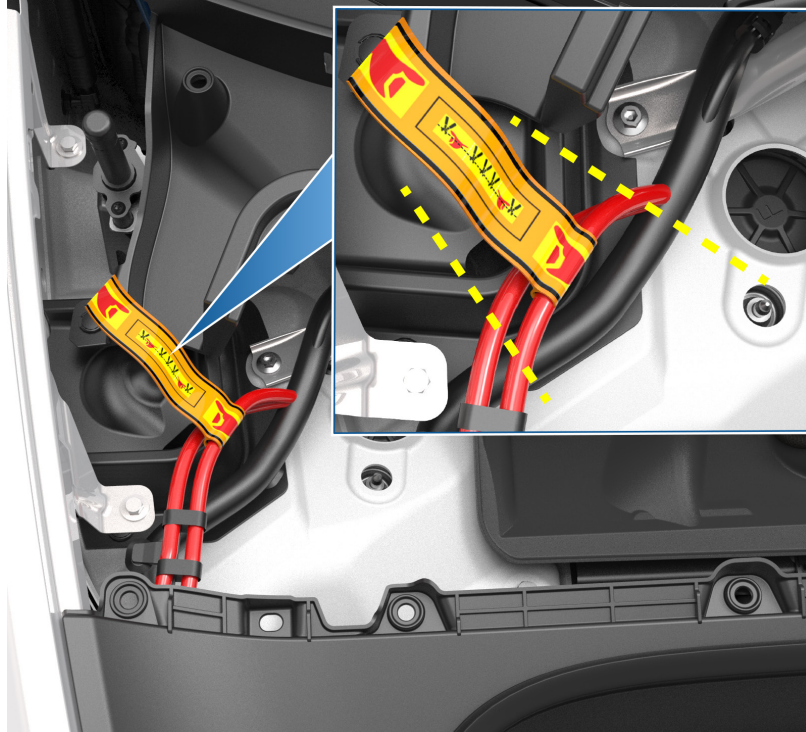

### ALTERNATIVE DISABLING METHOD

1. Break the fixed back window on the right side of the vehicle.
2. Remove the trim covering the internal wiring.
3. Double cut the first responder loop and then remove the cut section.

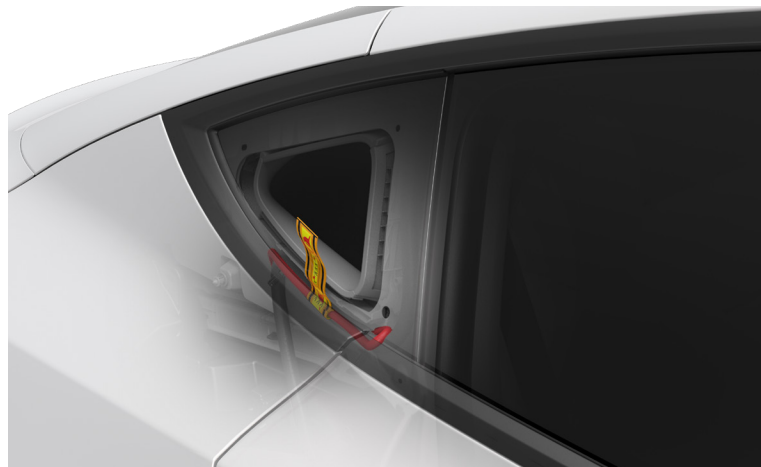

## COMPLETE DE-POWER

A complete de-power of the vehicle cuts power to the low voltage and high voltage systems. A de-power disables all electrical systems, as well as basic vehicle functionality such as moving seats and interacting with the touchscreen. Note also that cutting the cables of the low voltage battery alone doesn't necessarily disable the low voltage system due to system redundancies. You must cut the First Responder Loop as well to ensure that the vehicle is de-powered.

1. Access the First Responder Loop under the hood or behind the rear quarter side window.
2. Double cut the First Responder Loop and then remove the cut section.
3. Double cut the negative cables to the low voltage battery.
4. Wait 2 minutes for the vehicle to finish de-powering.



**WARNING** Regardless of the disabling procedure you use, ALWAYS ASSUME THAT ALL HIGH VOLTAGE COMPONENTS ARE ENERGIZED! Cutting, crushing, or touching high voltage components can result in serious injury or death.



**WARNING** When using the high voltage shut down methods recommended by this document, high voltage power is isolated to the high voltage battery. The high voltage battery is always energized.



## Opening the Hood using an External Low Voltage Power Supply

If low voltage power is not available, you might need an external power supply to access the hood and cut the first responder loop. This method will not open the frunk if the Robotaxi vehicle is locked and has low voltage power. Use an external power supply, such as a jumper box, for the following:

1. Release the tow eye cover by pressing firmly on the top right perimeter of the cover until it pivots inward, then pulling the raised section toward you.



2. Pull the two wires out of the tow eye opening to expose the vehicle-side terminals.
3. Connect the external low voltage power supply's red positive (+) cable to the red positive (+) vehicle-side terminal.
4. Connect the external low voltage power supply's black negative (-) cable to the black negative (-) vehicle-side terminal.

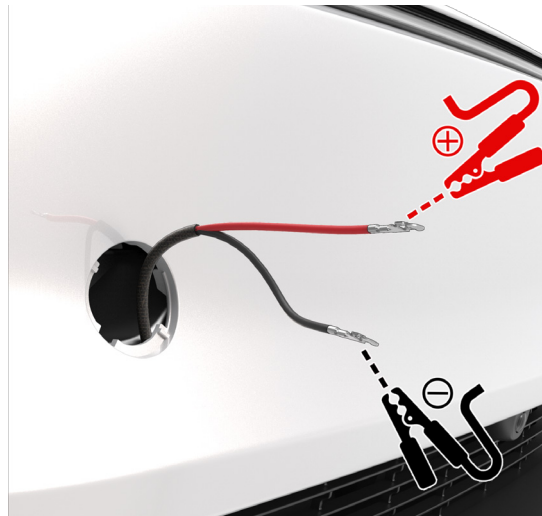

5. Turn on the external power supply (refer to the manufacturer's instructions of your external power supply). The hood latches are immediately released and you can open the hood to access the frunk area.
6. Disconnect both external power supply cables, beginning with the black negative (-) cable.

## 9. Access to the occupants

Consult the appropriate Emergency Response Guide at <https://www.tesla.com/firstresponders> for more details around accessing the vehicle.

**NOTE:** The seats, steering wheel, and doors are electrically powered and may not function after a safety critical event.

**NOTE:** After a safety critical event, the doors and liftgate may not open from the outside. Extrication may be required.

### Keys

Robotaxi does not require physical keys for vehicle access. Robotaxi automatically unlocks and opens the doors when picking up or dropping off passengers. Doors can otherwise be locked or unlocked directly on the front touchscreen console. If the vehicle is unoccupied when stopped by a first responder, the passenger doors automatically unlock when Autonomous Mode disengages. In the event of a collision, Robotaxi is designed to automatically unlock the doors for easier egress.

Tesla recommends that first responders reach out to Tesla Robotaxi Support to remotely open the doors of a Robotaxi.

### Opening Doors from the Outside with Power

To open the Robotaxi doors from the outside while power is available, contact Tesla Robotaxi Support. A Tesla Support Specialist can then open the door remotely. If the doors are unlocked, press the wide part of a door handle inwards and then pull the door open.

**NOTE:** You can also open a front door manually by reaching inside the window and using the mechanical release handle. See Opening Front Doors from Inside without Power.

### Opening Doors from Inside with Power

To open the Robotaxi doors from the inside with low voltage power available, press the button located near the door panel.



## Opening the Front Doors from Inside without Power

To open the Robotaxi front doors from the inside without low voltage power, lift the mechanical release handle located inside the door panel.



## Opening Rear Doors from Inside without Power

To open the rear doors from the inside without low voltage power:

1. At the bottom of the rear door pocket, there is a slot in front of the release cover. Slide your finger into the slot to remove the cover.
2. Pull the mechanical release cable forward.



## Opening Doors from Outside without Power

To open the Robotaxi doors from the outside without low voltage power, break the glass window of the "driver" or passenger seats and then lift the mechanical release handle.

It is important to know that in any vehicle collision with damage to the "driver" or passenger door, the mechanical door release may not operate as designed. It is also important to remember that every vehicle accident is different and such scenarios may require extrication operations to gain access to the vehicle cabin.



### Opening the Liftgate with Low Voltage Power

Use one of the following methods to open the liftgate:

1. Contact Tesla Robotaxi Support and request that they open the vehicle liftgate.
2. Access the vehicle cabin. On the touchscreen of Robotaxi, touch Open Trunk.
3. Press the switch located under the exterior handle on the liftgate.



### Opening the Hood with Power

Robotaxi does not have a traditional internal combustion engine. To open the hood with low voltage power enabled, contact Tesla Robotaxi Support.



### Opening the Hood using External Low Voltage Power Supply

You can use an external power supply, such as a jumper box, to provide enough energy to open the hood of the vehicle. This method does not open the hood if Robotaxi is locked and has low voltage power. Check the emergency response guide of the vehicle for details on powering the car.

## 10. Towing / transportation / storage

The rear motor in Robotaxi can generate power when the wheels spin. Before transporting the vehicle, contact Tesla Robotaxi Support and request that a Tesla Support Specialist enable Tow Mode for the vehicle. Always transport with all four tires off of the ground. Ensure that the tires are unable to spin at any time during transport.



**WARNING** NEVER TRANSPORT THE VEHICLE WITH THE TIRES IN A POSITION WHERE THEY CAN SPIN. DOING SO CAN LEAD TO SIGNIFICANT DAMAGE AND OVERHEATING. IN RARE CASES EXTREME OVERHEATING MAY CAUSE THE SURROUNDING COMPONENTS TO IGNITE.



**WARNING** POSSIBLE BATTERY RE-IGNITION! AFTER A FIRE INCIDENT, STORE OUTSIDE AT A SAFE DISTANCE (50 FT/15 M) FROM OTHER VEHICLES AND STRUCTURES!



A roll-back truck or comparable transport vehicle is the recommended method of transport. The vehicle can face either direction when using a flatbed. If the vehicle must be transported without a roll-back truck, then wheel lifts and dollies must be used to ensure that all four wheels are off of the ground. This method must not exceed the manufacturer speed rating of the dollies. With this method, Tesla recommends the vehicle faces forward so that the front wheels are lifted and the rear wheels are on dollies.

**NOTE:** The tires are allowed to rotate slowly (under 3 mph or 5 km/h) and for a very short distance (less than 30 feet or 10 meters) only when Tow Mode is enabled while the vehicle is being winched onto a flatbed truck or pulled out of a parking space for repositioning. Exceeding these boundaries can lead to significant damage and overheating.

**NOTE:** Ensure that Tow Mode is enabled by a Tesla Support Specialist before winching the vehicle onto a flatbed truck. If Tow Mode cannot be enabled, self-loading dollies or tire skates must be used to load the vehicle into the approved transportation position. Tesla is not responsible for any damage caused by or during transport of the vehicle, including personal property damage or damage caused by using self-loading dollies or tire skates.



**WARNING** The vehicle is equipped with high voltage components that may be compromised as a result of a collision. Before transporting, it is important to assume these components are energized. Always follow high voltage safety precautions (wearing personal protective equipment, etc.) until emergency response professionals have evaluated the vehicle and can accurately confirm that all high voltage systems are no longer energized. Failure to do so may result in serious injury.

## Moving the Vehicle



**WARNING** The following instructions are intended to be used when only moving Robotaxi a very short distance to improve traffic safety.



**WARNING** Pushing Robotaxi when it is not in Neutral or Tow Mode can result in overheating the motor and potential risk of shock if electrical components are exposed, even if the first responder loop has been cut.

In situations where there is minimal risk of fire or high voltage exposure (for example, the vehicle does not accelerate after coming to a stop at an intersection) and low voltage power is present, Robotaxi can be quickly pushed or driven in order to clear the roadway.

Request that Tesla Robotaxi Support shift Robotaxi to Neutral or enable Tow Mode and then move the vehicle. Inform the Tesla representative when the vehicle is ready to be immobilized.

If the vehicle has low or minimal damage, you can also request control of the vehicle from Tesla Robotaxi Support to briefly drive or move the vehicle to a safer location. You must be in uniform and prepared to show a badge or official identification to the camera on the B-pillar of the Robotaxi vehicle in order to be granted access to the vehicle controls.

**NOTE:** If you need to enable Tow Mode yourself, obtain access to the controls of the vehicle and then navigate to **Controls > Service > Towing > Enter Tow Mode**. For more information about Tow Mode, consult the [Owner's Manual](#).

**NOTE:** Low voltage power is required for Tow Mode to activate.

**NOTE:** Tow Mode automatically cancels and the parking brake is applied if Robotaxi is rolled faster than 5 mph (8 km/h) or low voltage power becomes low or absent. Robotaxi sounds its horn if Tow Mode is about to cancel.

**NOTE:** The touchscreen is unresponsive if Robotaxi has no low voltage power. Use an external low voltage power to open the hood and jump start the vehicle's auxiliary low voltage battery. Consult the appropriate Emergency Response Guide for more details.

**NOTE:** If airbags are deployed, you cannot drive Robotaxi. Do not push or move the vehicle unless you can enable Tow Mode. Otherwise, you must first secure the wheels for transport.

## Driving the Vehicle

Robotaxi uses a Model Y variant. Tesla vehicles operate differently from many other vehicles. Tesla recommends that first responders who haven't operated a Tesla vehicle should familiarize themselves with the controls before attempting to drive the vehicle. The interior cabin of Robotaxi should appear as follows:

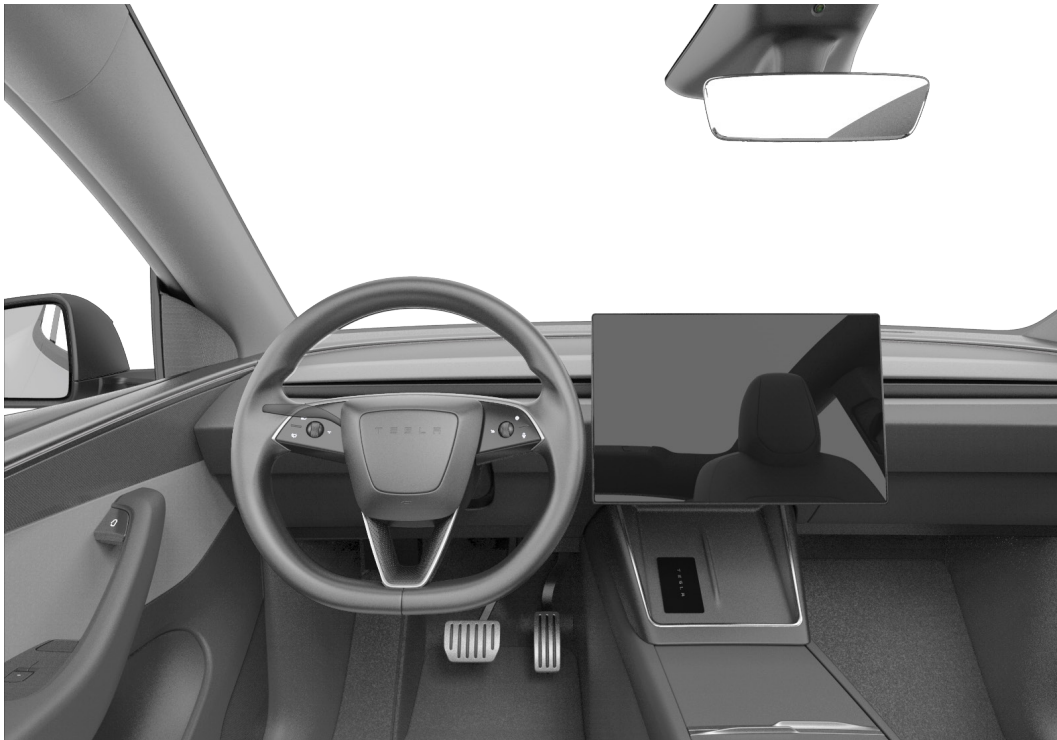

After receiving access to the vehicle controls:

1. Press the Brake pedal to wake the vehicle and enable shifting.
2. Shift the vehicle into Reverse, Drive, or Neutral using the drive mode strip on the left-side of the touchscreen or the manual drive mode selector on the overhead console.
  - A. Hold down the Brake pedal to shift with the overhead console.
  - B. Robotaxi vehicles in Drive and Reverse do not move until the accelerator is pressed.
3. If in Drive or Reverse, press the Accelerator pedal to move the vehicle.
4. Touch P on the drive mode strip or overhead console to Park the vehicle.

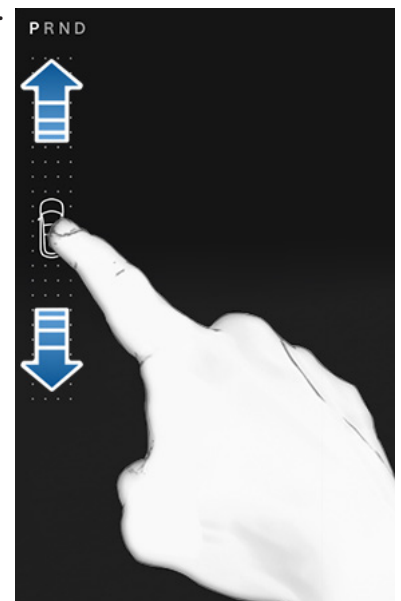

For additional information about a Tesla Model Y vehicle, consult the Owner's Manual at:

[https://www.tesla.com/ownersmanual/modely/en\\_us/](https://www.tesla.com/ownersmanual/modely/en_us/)

## 11. Important additional information

This document contains important instructions and warnings that must be followed when handling Robotaxi in an emergency situation.



**WARNING** Always use appropriate rescue tools and always wear appropriate PPE. Failure to follow these instructions can result in serious injury or death.



**WARNING** Regardless of the disabling procedure you use, ALWAYS ASSUME THAT ALL HIGH VOLTAGE COMPONENTS ARE ENERGIZED! Cutting, crushing, or touching high voltage components can result in serious injury or death.



**WARNING** After deactivation, the high voltage circuit requires 2 minutes to de-energize.



**WARNING** The RCM (Restraint Control Module) has a backup power supply with a discharge time of approximately 10 seconds. Do not touch the RCM (under the center console) within 10 seconds of an airbag or pre-tensioner deployment.



**WARNING** When cutting the first responder loop, double cut the loop to remove an entire section. This mitigates the risk of the cut wires accidentally reconnecting.



**WARNING** When using recommended high voltage shut down methods, high voltage power is isolated to the high voltage battery. The high voltage battery is always energized.



**WARNING** Never transport Robotaxi with wheels on the ground. Doing so can lead to significant damage and overheating. In rare cases, extreme overheating may cause the surrounding components to ignite.

### Additional Resources

First Responders and Second Responders with emergencies, call Tesla Robotaxi Support. Tesla Robotaxi Support can be reached via Tesla Roadside Assistance at 877 798 3752. The Robotaxi first responder information can be found at <https://www.tesla.com/firstresponders/robotaxi>. First responders and training officers who have questions, contact [firstrespondersafety@tesla.com](mailto:firstrespondersafety@tesla.com).



# TESLA MODEL Y

From 2025—Present  
5 doors / 5 seats / SUV



# Robotaxi

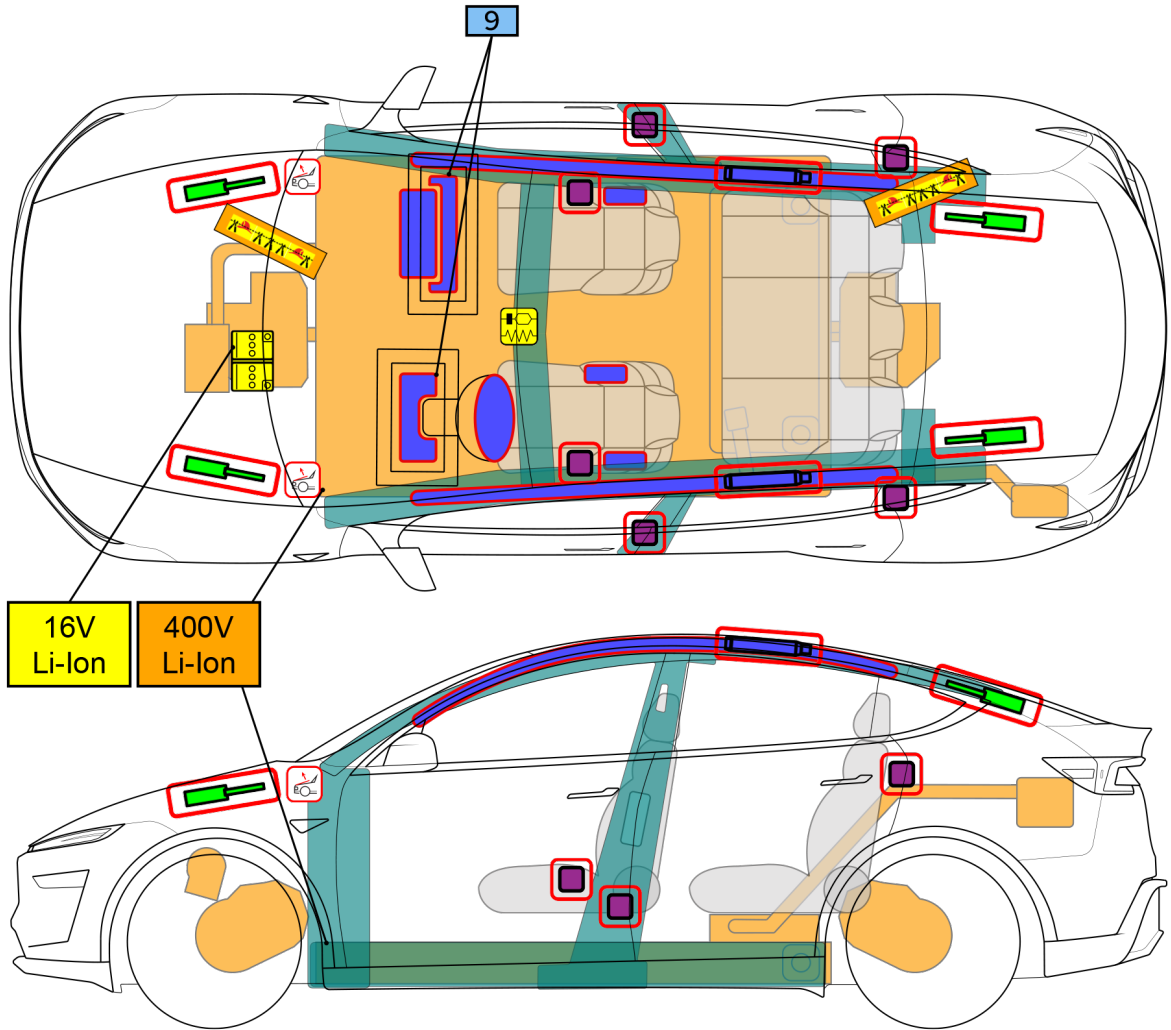

NOTE: Not all features present in all trims.

	Airbag		SRS control unit		Stored gas inflator		Seat belt pre-tensioner		Gas strut / Preloaded spring
	Battery low voltage		Battery pack, high-voltage		High voltage power cable		Cable cut		High strength zone
	Pedestrian protection active system (if equipped)								



## 1. Identification / Recognition



LACK OF ENGINE NOISE DOES NOT MEAN VEHICLE IS OFF. QUIET MOVEMENT OR INSTANT RESTART CAPABILITY EXISTS UNTIL VEHICLE IS FULLY SHUT DOWN.

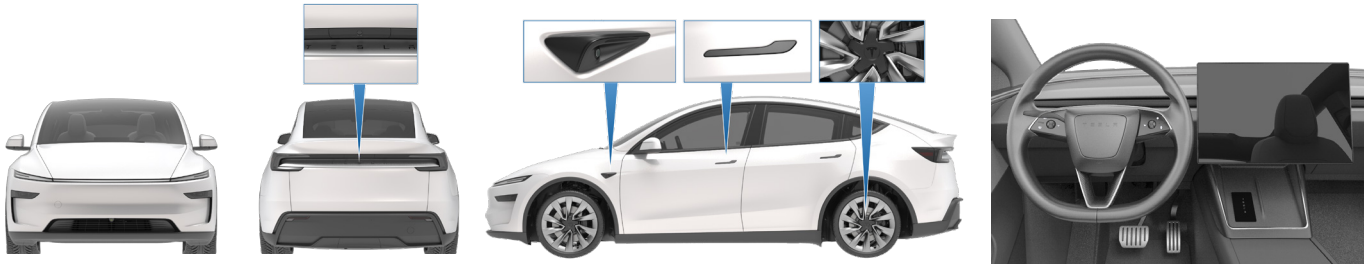

NOTE: The Tesla wordmark indicates a fully electric vehicle.

NOTE: The Robotaxi label in gold lettering on the front and rear fascia indicates a dedicated Robotaxi vehicle.

## 2. Immobilization / Stabilization / Lifting

### IMMOBILIZATION

NOTE: Ensure that you see rapidly flashing hazard lights or deployed airbags.

1. CONTACT TESLA ROBOTAXI SUPPORT
2. CAGE THE VEHICLE
3. CHOCK WHEELS



4. DISABLE AUTONOMOUS MOVEMENT
  - Open a cabin door.
  - Unbuckle a seatbelt.

### STABILIZATION / LIFTING POINTS

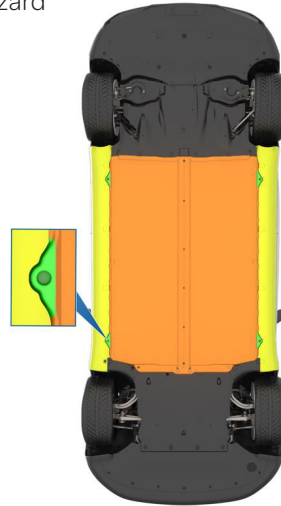

	Appropriate lift areas
	Safe stabilization points for Model Y resting on its side
	High Voltage (HV) Battery



Do not push on High Voltage Battery.



## 3. Disable Direct Hazards / Safety Regulations

### ACCESS

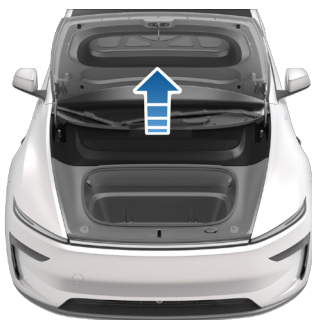

### MAIN DISABLING METHOD

- Open the hood.
- Double cut the first responder loop.

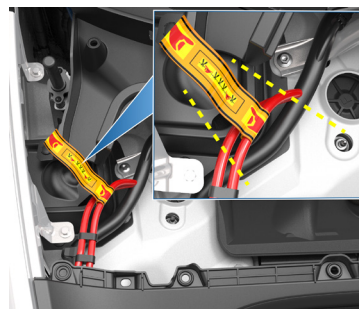

### ALTERNATIVE DISABLING METHOD

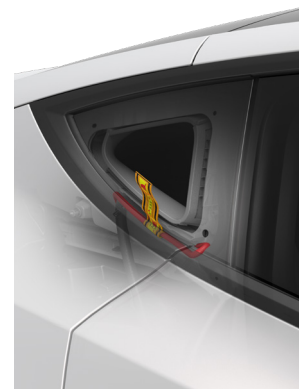

- First responder loop is located on the right side of Model Y.
- Break fixed window and remove trim to access.



Not every high voltage component is labeled. Always wear appropriate PPE. Always double cut the first responder loop. Do not attempt to open the high voltage (HV) battery.





## 4. Access to the Occupants









Electrical and mechanical releases like doors and seat belts may be compromised after a collision. Similarly, seats, steering wheel, and interior door buttons are electrically powered and may not function after a collision.





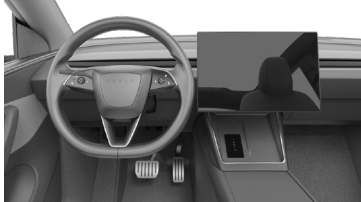

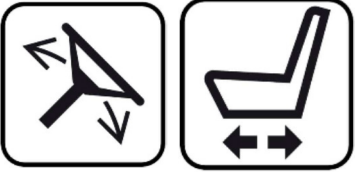
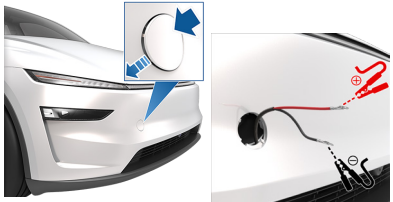
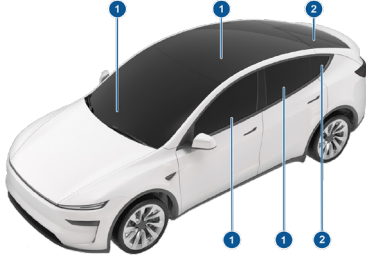
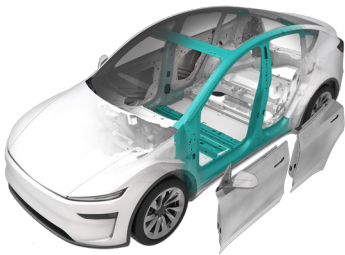

NOTE: Robotaxi vehicles are designed to automatically roll down windows, initiate two-way communication between Tesla Robotaxi Support and the vehicle cabin, and unlock all doors after a safety critical event.

NOTE: Robotaxi is designed to disengage autonomous activities upon detecting a safety critical event. Confirm that the vehicle is stationary and the hazard lights are flashing rapidly or that the airbags are deployed.



NOTE: Severe collisions may cause doors to be mechanically difficult to operate. Extrication may be required. The body is constructed of steel with aluminum doors.

<p><b>OPENING DOORS FROM OUTSIDE WITH POWER</b></p> 	<p><b>OPENING DOORS FROM INSIDE WITH POWER</b></p> 	<p><b>OPENING TRUNK FROM OUTSIDE WITH POWER</b></p> 	<p><b>OPENING HOOD FROM INSIDE WITH POWER</b></p> <ul style="list-style-type: none"> <li>Touch the open hood button on the touchscreen</li> </ul> 
<p><b>OPENING FRONT DOORS FROM INSIDE WITHOUT POWER</b></p> 	<p><b>OPENING REAR DOORS FROM INSIDE WITHOUT POWER</b></p> 	<p><b>NON-OPERATIONAL WITHOUT POWER</b> </p> 	<p><b>OPENING HOOD WITHOUT POWER</b></p> <ul style="list-style-type: none"> <li>Use external power supply to OPEN</li> </ul> 
<p><b>GLASS</b></p> <ol style="list-style-type: none"> <li>LAMINATED</li> <li>TEMPERED</li> </ol> 	<p><b>HIGH STRENGTH ZONES</b></p> <ul style="list-style-type: none"> <li>STEEL VEHICLE STRUCTURE</li> <li>ULTRA-HIGH STRENGTH STEEL A/B PILLARS</li> <li>ALUMINUM DOORS</li> </ul>		

## 5. Stored Energy / Liquids / Gases / Solids

			16V Low Voltage
			400V Li-Ion

 All high voltage cables have **ORANGE INSULATION**.

  Coolant is blue or orange.

 Never cut or open high voltage components or cables.



**TESLA MODEL Y**  
From 2025—Present  
5 doors / 5 seats / SUV



## 6. In Case of Fire

**DO NOT SUBMERGE VEHICLE TO EXTINGUISH/COOL BATTERY FIRE**

**USE LARGE AMOUNTS OF WATER TO COOL THE BATTERY ENCLOSURE FROM THE BOTTOM OF THE VEHICLE**

**POSSIBLE BATTERY RE-IGNITION!**

**MONITOR HV BATTERY TEMPERATURE FOR AT LEAST 24 HOURS**

## 7. In Case of Submersion

Treat a submerged Robotaxi like any other submerged vehicle. Wear appropriate PPE for water rescue. Remove the vehicle from the water and continue with normal high voltage disabling. Vehicles submerged in water should be handled with a greater potential risk of an HV battery fire. Raise the front of the vehicle approximately 30 cm (1 foot) to allow water to drain out of the vehicle and battery pack and then store the vehicle flat.

## 8. Towing / Transportation / Storage

Use a towing truck with flatbed.

**NO** towing with running traction wheels.

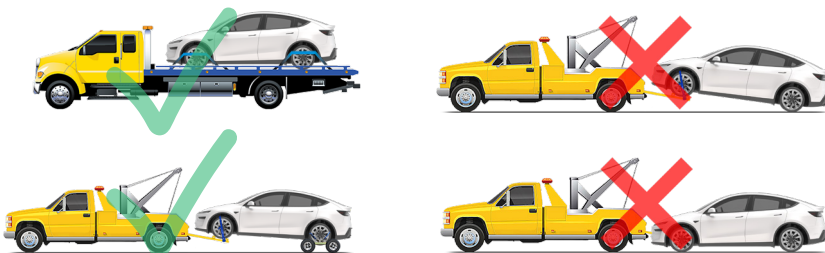

**HV BATTERY TEMPERATURE SHOULD BE CHECKED BEFORE TRANSPORT**

**POSSIBLE BATTERY RE-IGNITION!**  
**AFTER A FIRE INCIDENT, STORE OUTSIDE AT A SAFE DISTANCE (AT LEAST 50 FT/ 15 M) FROM OTHER VEHICLES AND STRUCTURES!**

To move the vehicle, request control of the vehicle from Tesla Robotaxi Support to briefly drive or move the vehicle to a safer location. Must be in uniform and prepared to show identification to the camera on the B-pillar of the Robotaxi vehicle to be granted access to the vehicle controls.

Ensure that the vehicle is in Neutral or Tow Mode before attempting to push the vehicle.

## 9. Important Additional Information

First responder information can be found at <https://www.tesla.com/firstresponders>. First responders and training officers who have questions, contact [firstrespondersafety@tesla.com](mailto:firstrespondersafety@tesla.com).

Tesla provides vehicle data from accidents and incidents in response to requests from law enforcement. Such requests must be provided with the appropriate legal documentation, such as search warrants and subpoenas. For further instructions, see <https://ts.la/ler-guidelines>.

To check registration or insurance of the vehicle, contact Tesla Robotaxi Support.

<p><b>TESLA Model Y - Robotaxi</b> From 2025 - Present</p>	ID No.	Version No.	Page No.
	TESLA-2025MY-002-R	02	04/05



## 10. Explanation of Pictograms



In some working environments, the Infrared (IR) device is referred to as a Thermal Image Camera (TIC).

### Addendum: Tesla Robotaxi Support

First Responders with emergencies, call Tesla Robotaxi Support via Tesla Roadside Assistance at 877 798 3752. Prepare the following details when you reach out to Tesla Robotaxi Support:

- Your name.
- Your agency.
- Your badge number or identification number.
- The VIN or license plate of any Tesla vehicles involved.
- The location of the incident.

To redirect or geofence autonomous vehicle traffic due to road closure, construction, roadway maintenance, or emergency response, call Tesla Robotaxi Support via Tesla Roadside Assistance and provide:

- Your name.
- Your agency.
- Your badge number or identification number.
- Longitude and latitude of the closure.
- Reason for closure.
- Your phone number.

### Addendum: First Responder Interactions

#### Performing a Stop

To perform a stop on a Robotaxi vehicle as a first responder:

1. Pull up behind the Robotaxi vehicle.
2. Turn on your sirens and emergency vehicle lights.
3. Stay behind the Robotaxi vehicle as Robotaxi pulls over and parks. Wait for the vehicle to rapidly flash hazard lights, signifying that Autonomous Mode is disengaged.
4. Establish communications with Tesla Robotaxi Support.
  - A. Call Tesla Roadside Assistance at 877 798 3752 and request Tesla Robotaxi Support.
  - B. Approach the front "driver" window and speak directly via the on-board two-way communication system.
  - C. Touch Support on the front or rear touchscreen to manually initiate two-way communication.
5. (If possible) Confirm that the blue steering wheel icon is not present in the top left corner of the front touchscreen.
6. Immobilize the vehicle. See Chapter 2, Immobilization on page 2.
7. (If needed) Move the vehicle. Immobilize the vehicle again after moving.

#### Responding to an Incident

When responding to an incident involving a Tesla Robotaxi, such as a collision:

1. Pull up behind the Robotaxi vehicle.
2. Turn on your emergency vehicle lights. Ensure that you see Robotaxi rapidly flash hazard lights, signifying that Autonomous Mode is disengaged.
3. Establish communications with Tesla Robotaxi Support.
  - A. Call Tesla Roadside Assistance at 877 798 3752 and request Tesla Robotaxi Support.
  - B. Approach the front "driver" window and speak directly via the on-board two-way communication system.
  - C. Touch Support on the front or rear touchscreen to manually initiate two-way communication.
4. (If possible) Confirm that the blue steering wheel icon is not present in the top left corner of the front touchscreen.
5. Immobilize the vehicle. See Chapter 2, Immobilization on page 2.
6. (If needed) Cut the First Responder Loop to disable the vehicle. See Chapter 3, Disable direct hazards on page 2.
7. (If needed) Move the vehicle. Immobilize the vehicle again after moving.

#### Completing a Stop or Incident

To complete a stop or response to a Robotaxi vehicle:

1. Remove anything used to immobilize the vehicle.
2. Communicate completion of first responder activities to Tesla Robotaxi Support.
3. (If needed) Request additional assistance, such as towing and cleanup services.

 <b>TESLA Model Y - Robotaxi</b> From 2025 - Present	<b>ID No.</b>	<b>Version No.</b>	<b>Page No.</b>
	TESLA-2025MY-002-R	02	05/05



INFORMATION FOR FIRST AND SECOND RESPONDERS

EMERGENCY RESPONSE GUIDE

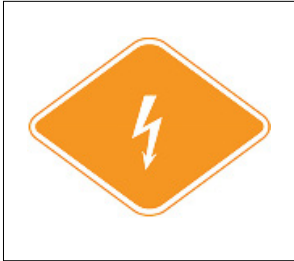

**TESLA**  
**MODEL Y 2025+**  
**ELECTRIC**



# CONTENTS

0. Rescue Sheet(s)	Page 1
1. Identification / recognition	Page 2
2. Immobilization / stabilization / lifting	Page 5
3. Disable direct hazards / safety regulations	Page 7
4. Access to the occupants	Page 15
5. Stored energy / liquids / gases / solids	Page 22
6. In case of fire	Page 26
7. In case of submersion	Page 28
8. Towing / transportation / storage	Page 29
9. Important additional information	Page 32
10. Explanation pictograms used	Page 33



# TESLA MODEL Y

From 2025—Present  
5 doors / 5 seats / SUV

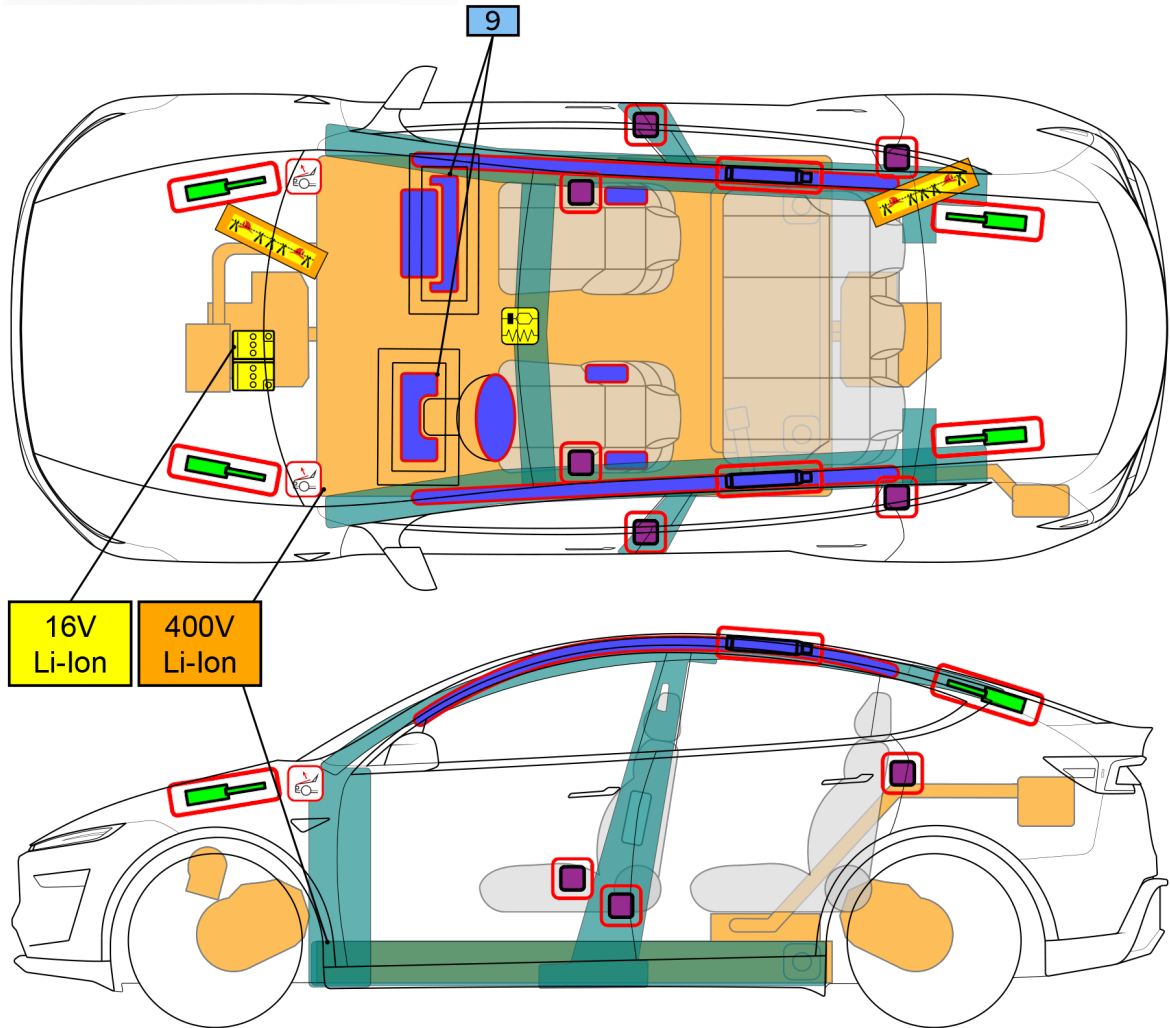

NOTE: Not all features present in all trims.

	Airbag		SRS control unit		Stored gas inflator		Seat belt pre-tensioner		Gas strut / Preloaded spring
	Battery low voltage		Battery pack, high-voltage		High voltage power cable		Cable cut		High strength zone
	Pedestrian protection active system								

## 1. Identification / recognition



**WARNING** LACK OF ENGINE NOISE DOES NOT MEAN VEHICLE IS OFF: SILENT MOVEMENT OR INSTANT RESTART CAPABILITY EXISTS UNTIL VEHICLE IS FULLY SHUT DOWN. WEAR APPROPRIATE PPE.

### Wordmark, Badging, and Door Handles

Model Y can be identified by the TESLA wordmark on the rear fascia and the uniquely shaped door handles. The model name does not appear on the vehicle.

The 2025 Model Y variant can be distinguished from other model years by the shape of the headlights and brake lights and the more angular front fascia.

**NOTE:** Model Y may have a "DUAL MOTOR" badge on the liftgate to indicate that it is a dual motor configuration.

**NOTE:** Model Y vehicles manufactured in Gigafactory Shanghai may have a Tesla emblem on the hood of the car.

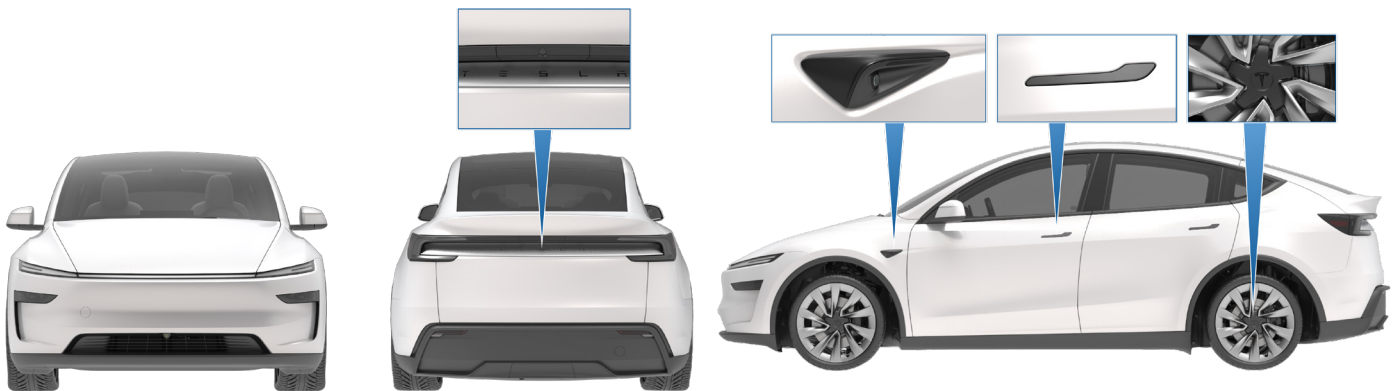

### Vehicle Identification Number (VIN)

Model Y can be identified by its VIN. Locate the stamped plate on the top of the dashboard by looking through the driver's side of the windshield. The VIN can also be found on the driver's side door pillar. On some vehicles, the VIN can alternatively be found either under the carpet beneath the front passenger seat or on a label stamped by the rear right door under the interior trim.

If the touchscreen is operational, you can check the VIN by navigating to **Controls > Software**.



## Touchscreen and Cabin

Model Y can be identified by the large touchscreen mounted in a “landscape” orientation. Model Y has a single stalk behind the steering wheel, whereas previous model years have two.

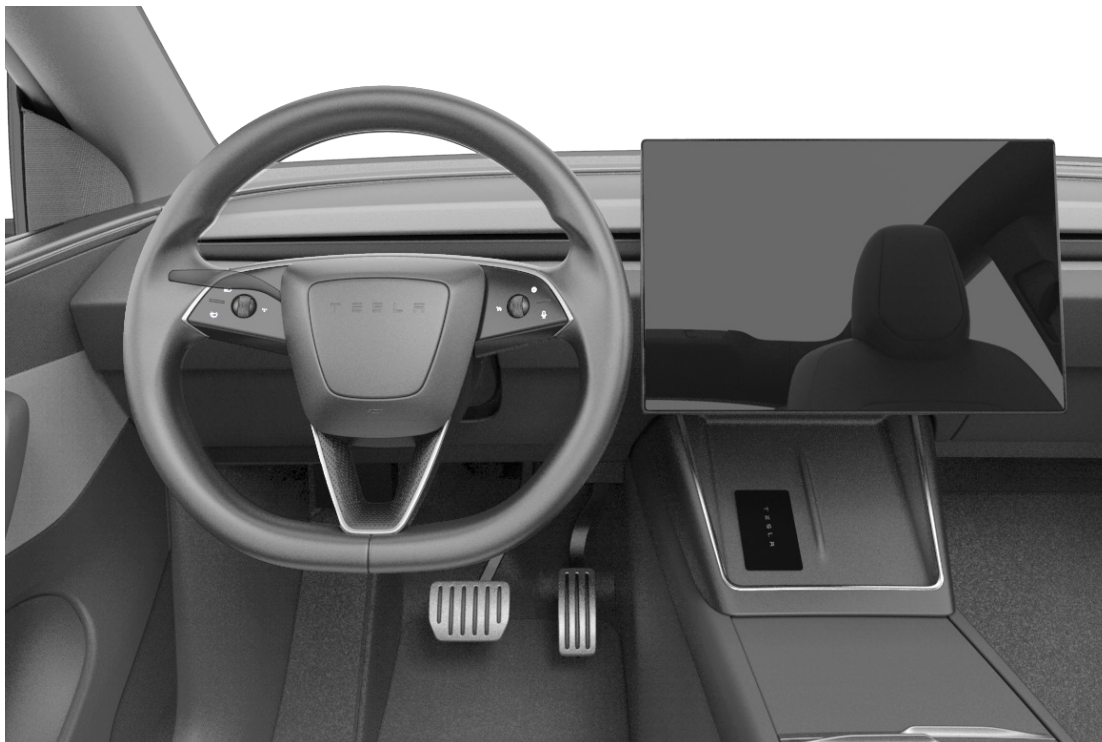

Refer to the [Owner's Manual](#) for information on touchscreen operation. After a collision or if vehicle airbags have deployed, low voltage power may not be available and the touchscreen will not be operational. Trying to support low voltage power on a vehicle that has been in an accident could lead to a possible electrical fire. We do not recommend attempting to reconnect low voltage power after an accident.

## Keys

Model Y supports 3 types of keys.

- **Authenticated phone** – A personal smartphone can be set up to communicate with Model Y using Bluetooth. If a smartphone is already paired to the vehicle, open the Tesla mobile app on the smartphone and navigate to CONTROLS to unlock or lock Model Y.
- **Key card** – Tap the Model Y key card on the driver's side door pillar to access the locked vehicle. You can also tap the key on the wireless phone charger to enable driving functionality.

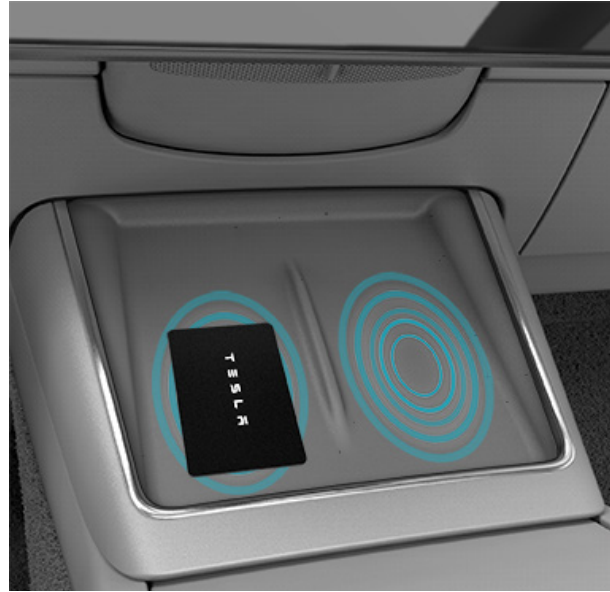

- **Key fob** – The key fob is shaped like a miniature Model Y. It allows you to press buttons to open the frunk and rear trunk and unlock, lock, and drive Model Y. Use the key buttons as shown below.



1. Frunk - Double-click to unlatch the frunk.
2. Lock/Unlock All - Single-click to lock doors and trunks (all doors and trunks must be closed). Double-click to unlock doors and trunks.
3. Rear trunk - Double-click to open or close the rear trunk. Hold down for one to two seconds to open the charge port door.

## 2. Immobilization / stabilization / lifting

### IMMOBILIZATION

#### 1. Chock wheels

Model Y moves quietly, so never assume it is powered off. Model Y may not move unless the accelerator pedal is pressed, even if shifted into Drive or Reverse. However, never assume that Model Y will not move. Always chock the wheels.



#### 2. Put vehicle into Park position

Pressing the accelerator pedal even slightly can cause Model Y to accelerate quickly if the active gear is Drive or Reverse. To ensure that the parking brake is engaged, press and hold the Park (P) button on the touchscreen to shift into Park and enable the parking brake. You can also press and hold Park (P) on the drive mode selector on the overhead console. Whenever Model Y is in Park, the parking brake is automatically engaged and the touchscreen shows the active gear as Park (P).



## STABILIZATION / LIFTING POINTS

The high voltage battery is located under the floor pan. A large section of the undercarriage houses the high voltage battery. When lifting or stabilizing Model Y, only use the designated lift areas, as shown in green.



**WARNING** Be careful to not damage the battery pack while stabilizing / lifting the vehicle.





**WARNING** The vehicle should be lifted or manipulated only if first responders are trained and equipped at the technician level per National Fire Protection Association (NFPA) and are familiar with the vehicle's lifting points. Use caution to ensure you never come into contact with the high voltage battery or other high voltage components while lifting or manipulating the vehicle.

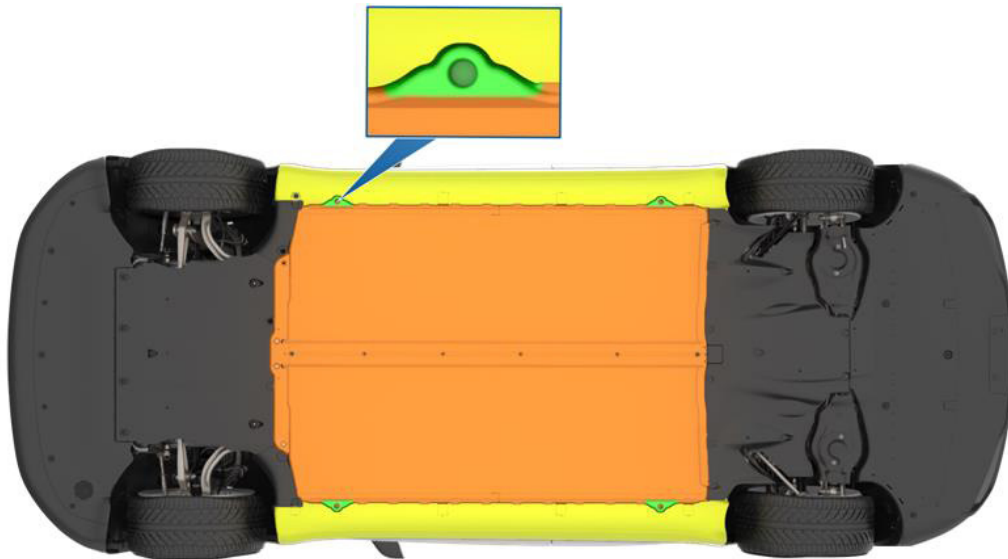

**WARNING** DO NOT USE THE HIGH VOLTAGE BATTERY TO LIFT OR STABILIZE MODEL Y.



	Appropriate lift areas
	Safe stabilization points for a Model Y resting on its side
	High voltage battery

### 3. Disable direct hazards / safety regulations

#### ACCESS

1. Open the hood (see chapter 4: Access to the Occupants).
2. Remove the access panel by pulling it upward to release the clips that hold it in place.

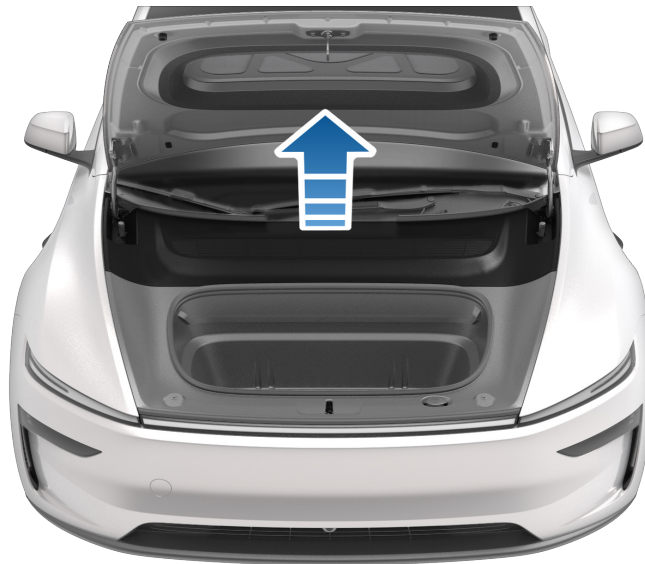

#### MAIN DISABLING METHOD

1. Double cut the first responder loop and then remove the cut section.

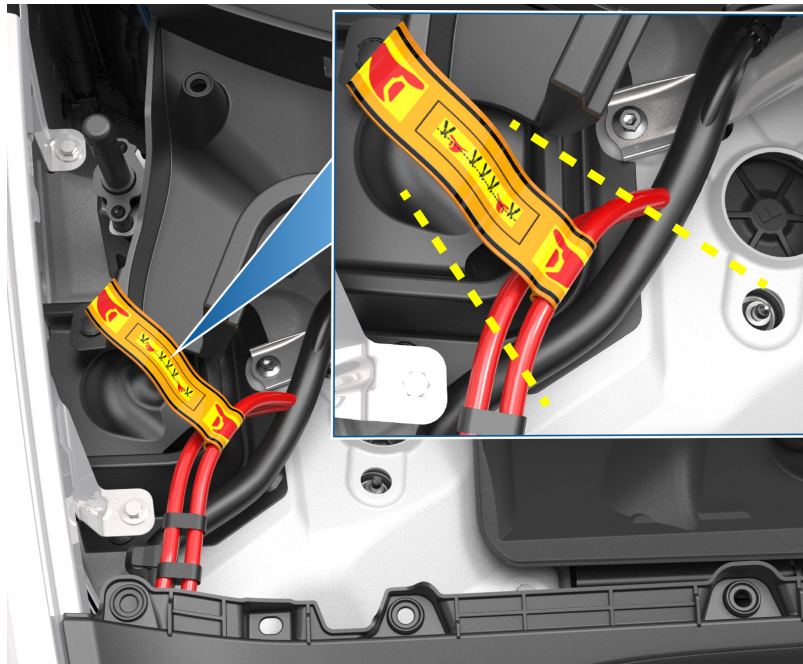

**WARNING** Not every high voltage component is labeled. Always wear appropriate PPE. Always double cut the first responder loop. Do not attempt to open the High Voltage (HV) battery.



## ALTERNATIVE DISABLING METHOD

1. Break the fixed back window on the right side of the Model Y.
2. Remove the trim covering the internal wiring.
3. Double cut the first responder loop and then remove the cut section.



## COMPLETE DE-POWER

A complete de-power of the vehicle cuts power to the low voltage system and high voltage systems. A de-power disables all electrical systems, as well as basic vehicle functionality such as moving seats and interacting with the touchscreen. Note also that cutting the cables of the low voltage battery alone doesn't necessarily disable the low voltage system due to system redundancies. You must cut the First Responder Loop as well to ensure that the vehicle is de-powered.

1. Access the First Responder Loop under the hood or behind the rear quarter side window.
2. Double cut the First Responder Loop and then remove the cut section.
3. Double cut the negative cables to the low voltage battery.
4. Wait 2 minutes for the vehicle to finish de-powering.



**WARNING** Regardless of the disabling procedure you use, ALWAYS ASSUME THAT ALL HIGH VOLTAGE COMPONENTS ARE ENERGIZED! Cutting, crushing, or touching high voltage components can result in serious injury or death.



**WARNING** When using the high voltage shut down methods recommended by this document, high voltage power is isolated to the battery. The high voltage battery is always energized.



## First Responder Loop Cable Cut

When cut, the First Responder Loop disables low voltage power going to the airbag circuit. Cutting of the First Responder Loop also removes low voltage power going to the high voltage contactors inside the high voltage battery pack, setting the high voltage contactors to "off," or "open." Cutting the low voltage battery cable may not disable all of the low voltage system, and it could disable the use of vehicle immobilization controls, seat controls, touch screen information, and other features.

The primary First Responder Loop is located under the hood on the passenger-side of the vehicle for left-hand drive vehicles and is in the same location for right-hand drive vehicles. There is a secondary First Responder Loop behind the rear right-passenger seat.

The high voltage contactors disconnect the High Voltage Battery from the rest of the high voltage components, like a light switch. When "open" or in the "off" position, high voltage is present only in the battery pack. When "closed" or in the "on" position, battery pack voltage is connected to the other high voltage components. On Model Y vehicles, those high voltage components include the rear drive unit, the front drive unit, the air conditioning compressor, and potentially the charge port. When you cut the First Responder Loop, the high voltage contactors open to isolate the high voltage to the battery pack.

When the vehicle has been in an accident and the First Responder Loop has been cut, always treat the pack and the high voltage components as if they are live, because the pack will still have stored energy within the cells and it is not known if other high voltage components have been damaged. Treat every orange cable and battery pack as if there is high voltage in them. Never cut an orange high voltage cable or cut into the battery pack.

There is no way to instantaneously discharge the energy that is inside of the battery pack when a vehicle is in an accident. There is stored energy in battery cells. Caution must be used to not damage the battery pack in the case of vehicle extrication operations.

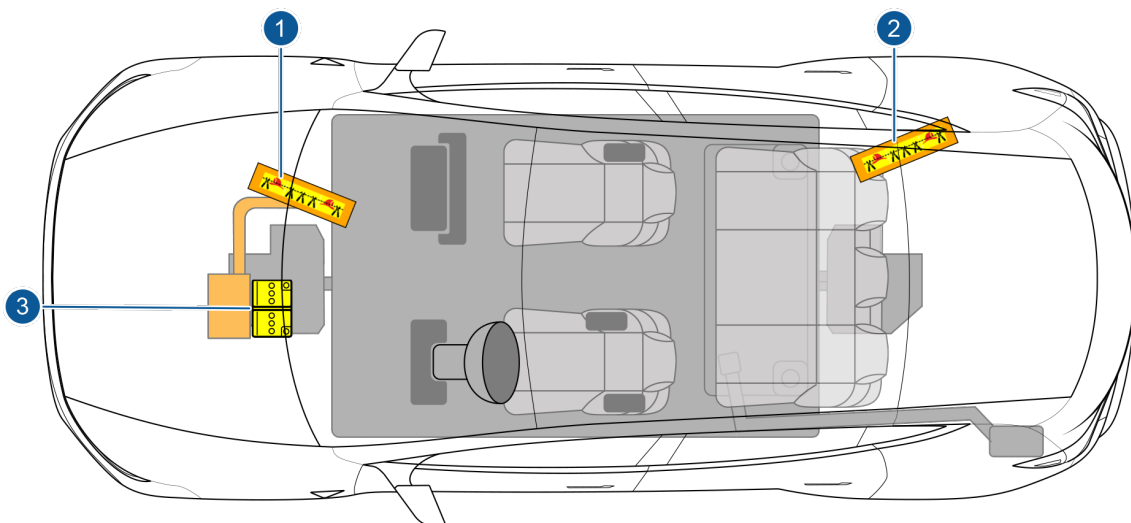

1. Primary First Responder Cut Loop
2. Secondary First Responder Cut Loop
3. 16V Low Voltage Battery

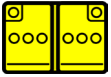

## Access to Low Voltage Battery

When the vehicle's hood is opened, the low voltage battery is accessible underneath the access panel next to the windshield. When necessary, the negative battery cable should be double cut to open the low voltage battery circuit. Care should always be taken to not cut both the positive and negative battery cables at the same time when double cutting the negative battery cable. Cutting both cables simultaneously can short circuit the low voltage battery.



## Disabling a Charging Vehicle

Before attempting to disable the vehicle, unplug the charging cable. If you have access to the cabin, touch **Controls > Charging > Unlock Charge port** on the touchscreen. You can also hold down the button on the charging cable of Tesla chargers if the car is unlocked or a paired key is nearby to unplug the cable without accessing the vehicle cabin.

If the car cannot be unplugged due to a damaged or locked charging cable, turn off power to the charging station. Then, proceed with disabling procedures by double cutting the First Responder Loop.



**WARNING** Do not cut the charging cable while the charging station has power. Cutting the charging cable while there is still power can start an electrical fire or cause severe injury.

## Manually Release Charging Cable

If you cannot unplug the charging cable and cannot disable the charging station, you can attempt to manually release the charging cable instead of cutting it.

1. Access the rear trunk.
2. Pull the charge port release cable downwards to unlatch the charger cable.
3. Pull the charger cable from the charge port.



**WARNING** Do not pull the release cable while simultaneously attempting to remove the charge cable from the charge port. Always pull the release cable before attempting to remove the charge cable. Failure to follow these instructions can result in electric shock and serious injury.



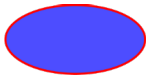

## Airbags

Airbags are located in the approximate areas shown. Airbag warning information is printed on the sun visors.

When the airbags have been deployed by the Restraint Control Module (RCM), the pyrotechnic fuse that deactivates the vehicle's high voltage system will be simultaneously triggered.

Model Y is designed to deactivate high voltage in all components and cables outside of the high voltage battery when an airbag is deployed. Care must be taken as to not cut any orange high voltage cables or try to gain access into the battery pack. Even though the high voltage system has shut down due to the airbags being deployed, it must always be assumed that there may be high voltage present in the high voltage cables and components. The battery cells within the battery pack will have stored energy and should not be compromised with rescue tools.

The First Responder Loop should be cut in order to open the low voltage circuit that provides power to the airbags. See the First Responder Loop section for more details.

**NOTE:** Left Hand Drive, North American vehicle shown. On Right Hand Drive vehicles, the components are mirrored.

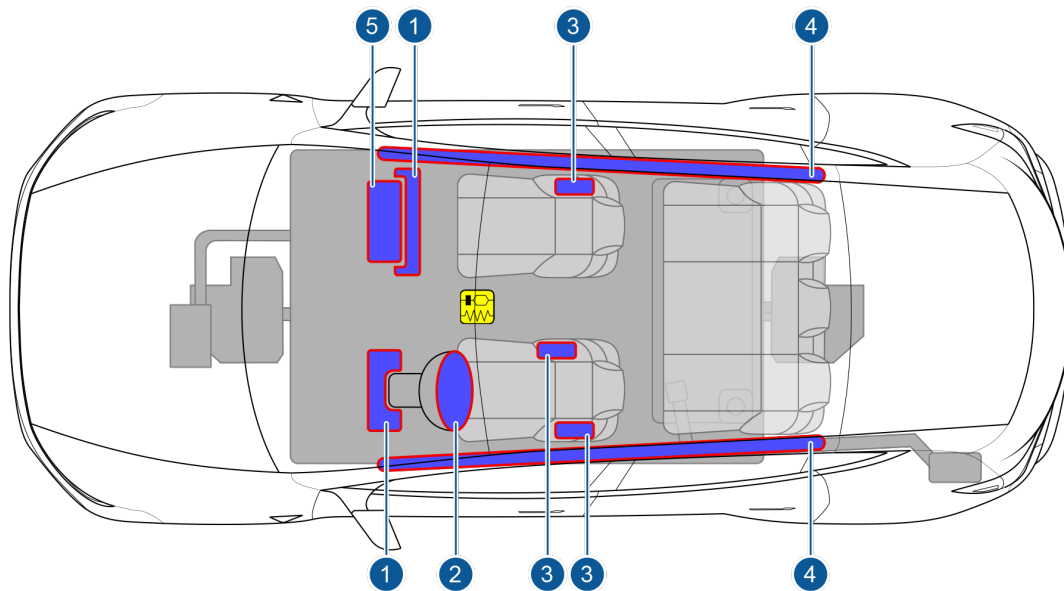

1. Knee airbags
2. Steering wheel airbag
3. Seat mounted side airbags
4. Curtain airbags
5. Passenger airbag



**WARNING** The RCM also has an internal energy reserve which allows it to remain powered for 10 seconds after both high voltage and low voltage power are disconnected. Do not touch the RCM within this 10 second time frame.



Knee airbags are only installed in North America, excluding Mexico.



## Stored Gas Inflators

The stored gas inflators, outlined in red, are located near the roof and towards the rear of the vehicle.

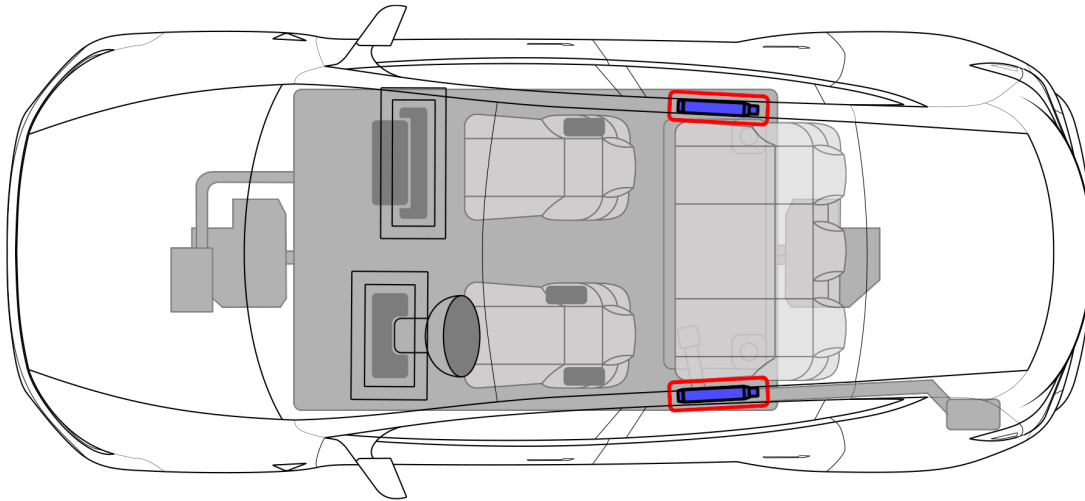

**WARNING** Rescuers should never cut or crush inflation cylinders. Cutting or compressing cylinders causes catastrophic failure, leading to injury or death.



**WARNING** The RCM has a backup power supply with a discharge time of approximately 10 seconds. Do not touch the RCM within 10 seconds of an airbag or pre-tensioner deployment.



## Seat Belt Pre-Tensioners

The seat belt pre-tensioners, outlined in red, are located at the bottom and top of the B-pillars. There are additional seat belt pre-tensioners located outboard of the 2nd row seats.

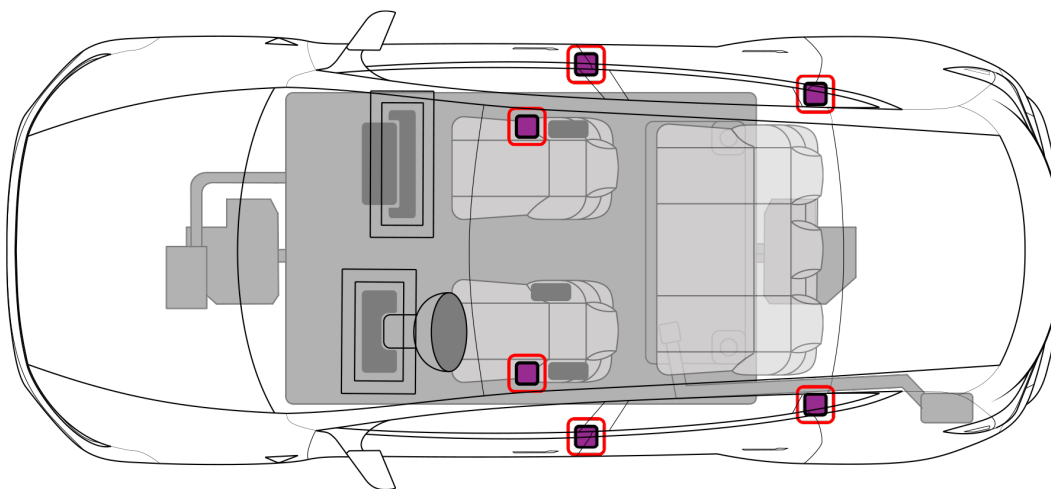



## Active Hood

The Active Hood pedestrian protection system is a safety feature that can detect an impact with a pedestrian while the vehicle is moving between approximately 30 and 52 km/hr (18 and 32 mph). When triggered, pyrotechnic actuators raise the rear portion of the hood to increase the space between the hood and the components beneath it.

If the vehicle is equipped with Active Hood, the pyrotechnic actuators are located under the hood towards the base of the windshield.

Note: The pyrotechnic actuators can also deploy when colliding with an animal, vehicle or other object.

Notes: Active Hood may not be installed in every market or configuration.



**WARNING** Rescuers should never cut or crush the pyrotechnic actuators. Cutting or compressing actuators can cause catastrophic failure, leading to injury or death.

## 4. Access to the occupants

**NOTE:** The seats, steering wheel, and interior door buttons are electrically powered and may not function after a collision. The steering wheel becomes difficult to move without low voltage power.

**NOTE:** After a collision, the doors and trunk may not unlock from the outside. Severe collisions may cause doors to be mechanically difficult to operate. Extrication may be required.

### Opening Doors from the Outside with Power

To open the Model Y doors from the outside, press the wide part of a door handle inwards and then pull the door open.

**NOTE:** If the door handles do not function, open a front door manually by reaching inside the window and using the mechanical release handle. See Opening Front Doors from Inside without Power.



### Opening Doors from Inside with Power

To open the Model Y doors from the inside with low voltage power available, press the button located near the door panel.



## Opening Front Doors from Inside without Power

To open the Model Y front doors from the inside without low voltage power, lift the mechanical release handle located near the window switches.



## Opening Rear Doors from Inside without Power

To open the Model Y rear doors from the inside without low voltage power:

1. At the bottom of the rear door pocket, there is a slot in front of the release cover. Slide your finger into the slot to remove the cover.
2. Pull the mechanical release cable forward.



Manual door releases are designed to be used only in situations when the vehicle has no power. It is important to know also that in any vehicle collision with damage to the driver or passenger front door, the mechanical door release may not operate as designed. Remember also that every vehicle accident is different and may require extrication operations to gain access to the vehicle's cabin.



## Opening the Trunk with Low Voltage Power

Use one of the following methods to open the trunk:

1. Touch the associated OPEN button on the touchscreen for the trunk.
2. Press the switch located under the exterior handle on the trunk.





## Moving the Front Seats with Power

Model Y has electrically powered seats that move with buttons located on the side of the seat closest to the door. The buttons operate only when low voltage power is enabled and can still be used after the First Responder Loop is cut if the low voltage system is intact.



1. Moves seat forward/backward and adjust the seat's height and tilt angle up/down.
2. Adjusts backrest.
3. Adjusts lumbar support.



## Opening the Hood with Power

Model Y does not have a traditional internal combustion engine. Therefore, the area that would normally house the engine is used as additional storage space. Tesla calls this area the "Front Trunk" or "Frunk".

To open the hood with low voltage power enabled, touch the associated OPEN button on the touchscreen.



## Opening the Hood using an External Low Voltage Power Supply

If low voltage power is not available, you might need an external power supply to access the hood and cut the first responder loop. This method will not open the frunk if Model Y is locked and has low voltage power. Use an external power supply, such as a jumper box, for the following:

1. Release the tow eye cover by pressing firmly on the top right perimeter of the cover until it pivots inward, then pulling the raised section toward you.



2. Pull the two wires out of the tow eye opening to expose the vehicle-side terminals.
3. Connect the external low voltage power supply's red positive (+) cable to the red positive (+) vehicle-side terminal.
4. Connect the external low voltage power supply's black negative (-) cable to the black negative (-) vehicle-side terminal.

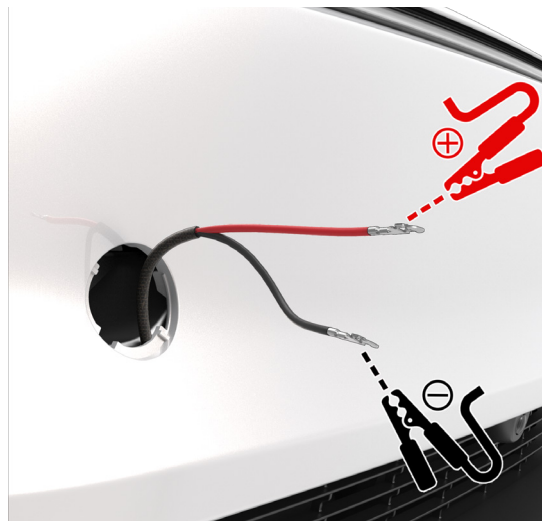

5. Turn on the external power supply (refer to the manufacturer's instructions of your external power supply). The hood latches are immediately released and you can open the hood to access the frunk area.
6. Disconnect both external power supply cables, beginning with the black negative (-) cable.



## High Strength Zone

Model Y is reinforced to protect occupants in a collision. Suitable tools must be used to cut or crush these areas. Reinforcements are shown in teal below.

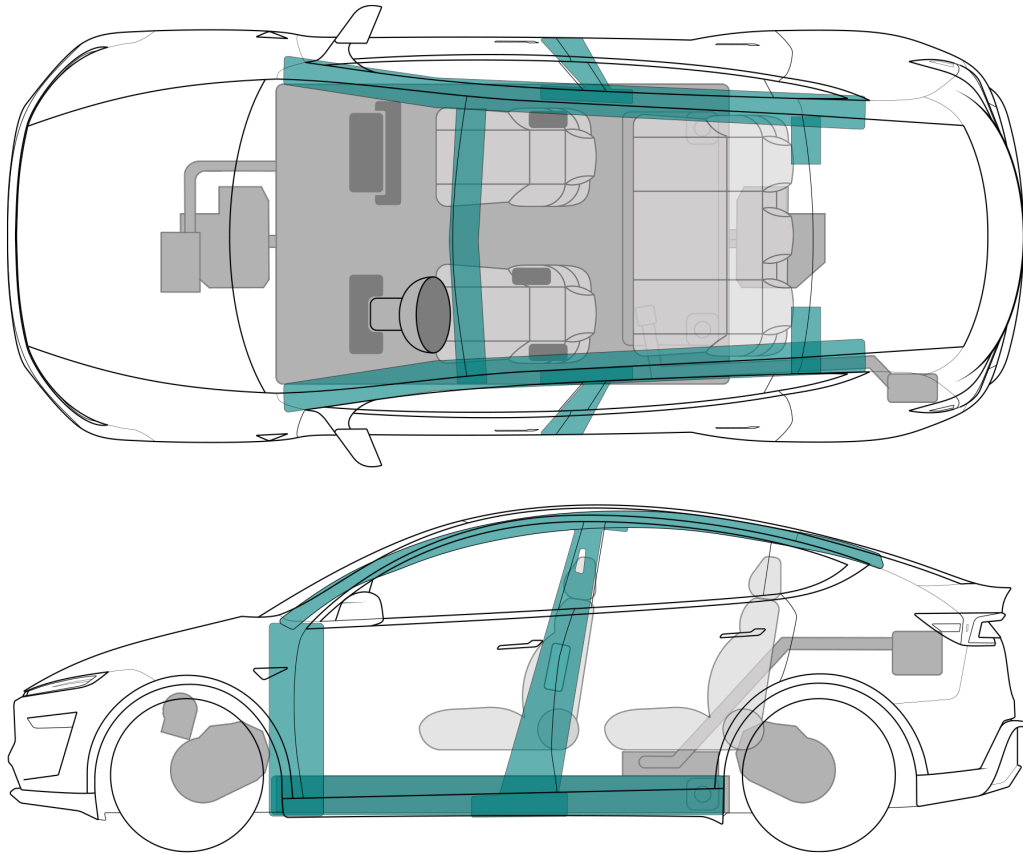

The A and B pillars, front door rings, and overhead rails of Model Y are constructed of ultra-high-strength reinforced steel. The vehicle's doors are made of aluminum. All other structural body components are made up of various strengths of steel or aluminum.



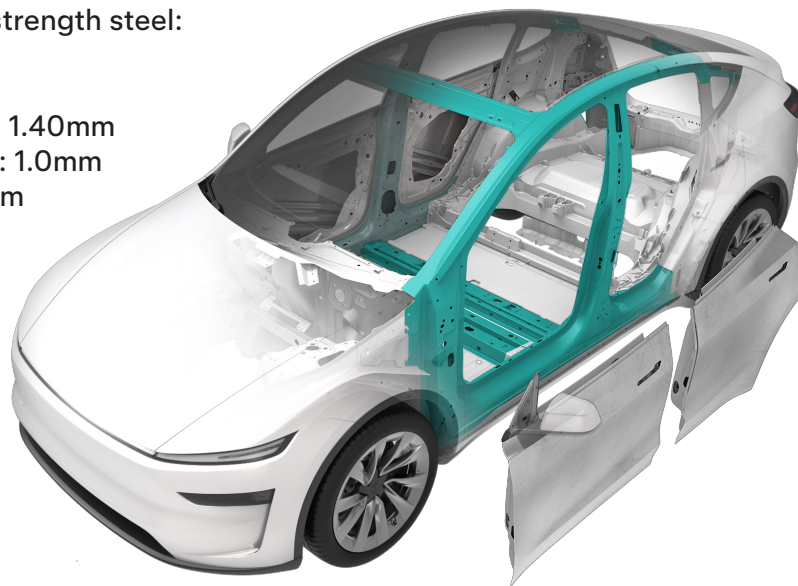

Maximum thickness of high strength steel:

1. Outer door ring: 1.80mm
2. Inner door ring: 2.0mm
3. Front overhead rail lower: 1.40mm
4. Front overhead rail upper: 1.0mm
5. Rear overhead rail: 1.40mm



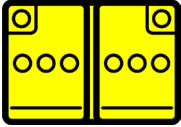

## 5. Stored energy / liquids / gases / solids

		16V
		400V



**WARNING** Clear liquid is likely water. Battery electrolyte is clear, but battery cells are sealed and have a limited volume of electrolyte per cell. The coolant is blue or orange.

**NOTE:** The following images show a Dual Motor vehicle. Vehicles without a front drive unit are similar.



### High Voltage Components

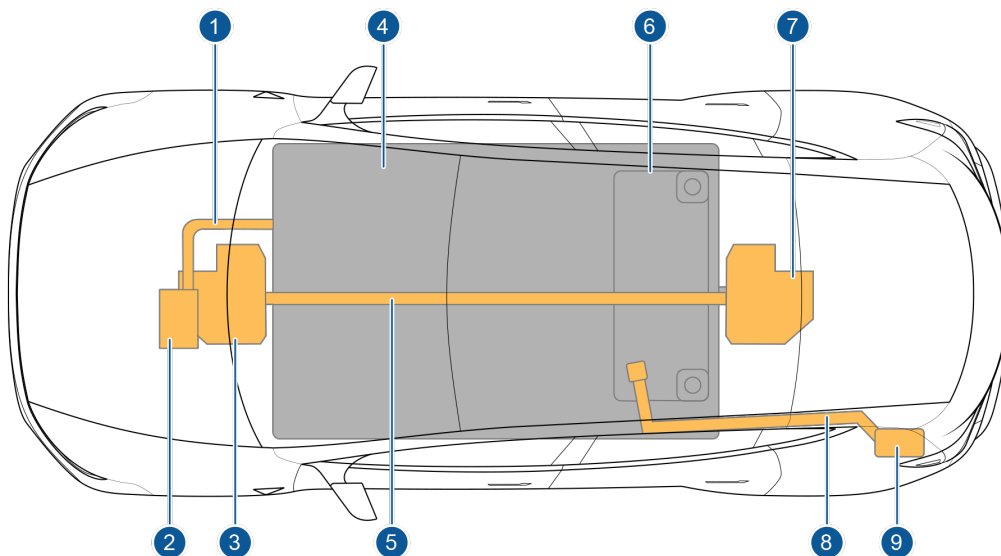

1. High Voltage Cabling
2. Air Conditioning Compressor
3. Front Motor (Dual Motor vehicles only)
4. High Voltage Battery
5. High Voltage Cabling
6. High Voltage Battery Service Panel
7. Rear Motor
8. High Voltage Busbars and Cables
9. Charge Port



## High Voltage Battery Pack

Model Y is equipped with a floor-mounted 400V lithium-ion high voltage battery. The battery is made up of many cells that are liquid cooled with coolant. The coolant will appear blue or orange in color and may leak from the battery pack if the pack has been compromised during a vehicle collision. The battery cells will have stored energy within them. Never breach the high voltage battery when lifting from under the vehicle. When using rescue tools, pay special attention to ensure that you do not breach the floor pan. Refer to Chapter 2: Lift Areas for instructions on how to properly lift the vehicle.

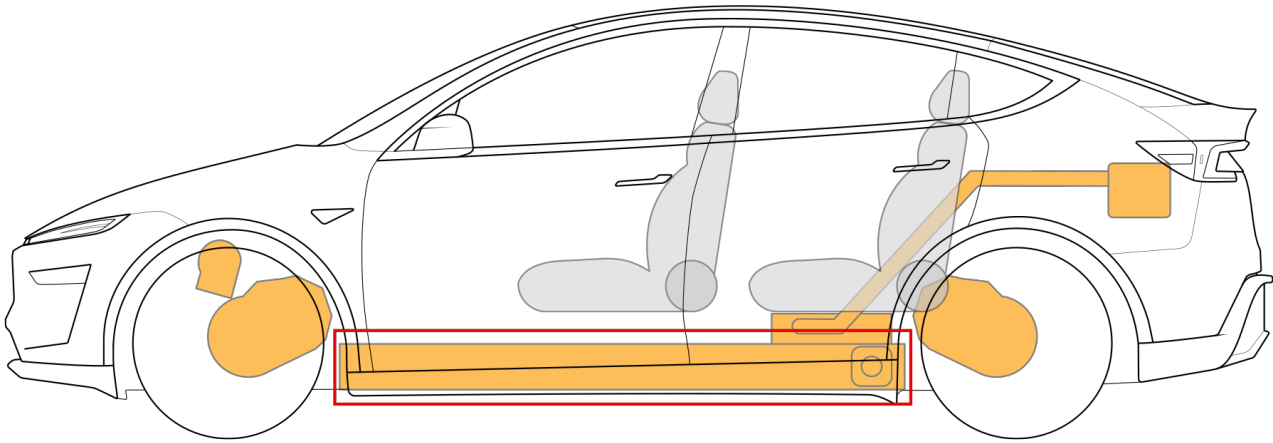

### Pushing on the Floor Pan

The high voltage battery is located below the floor pan. At no time should the high voltage battery pack be compromised with rescue tools.



**WARNING** Never push on the floor pan itself inside of Model Y. Doing so can breach the high voltage battery or damage the high voltage cables, which can cause serious injury or death.



## High Voltage Power Cable / Busbar / Component

High voltage cables and busbars are shown in orange. There are high voltage cables and busbars that run the length of the battery pack on the bottom side through an extrusion providing protection. Do not compromise these high voltage components with rescue tools. The assumption should be made that there may be high voltage present in the orange high voltage cables at all times.

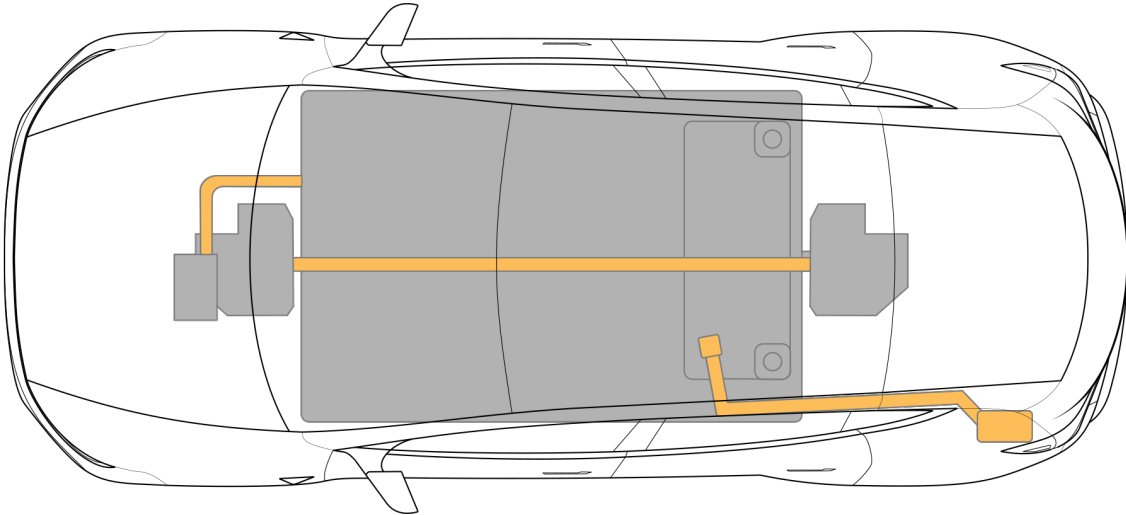

## Drive Units

The rear drive unit is located between the rear wheels, and the front drive unit (if equipped- Dual Motor vehicles only) is located between the front wheels. The drive inverter is located within the drive unit. The drive units convert Direct Current (DC) from the high voltage battery into Alternating Current (AC) that the drive units use to power the wheels.

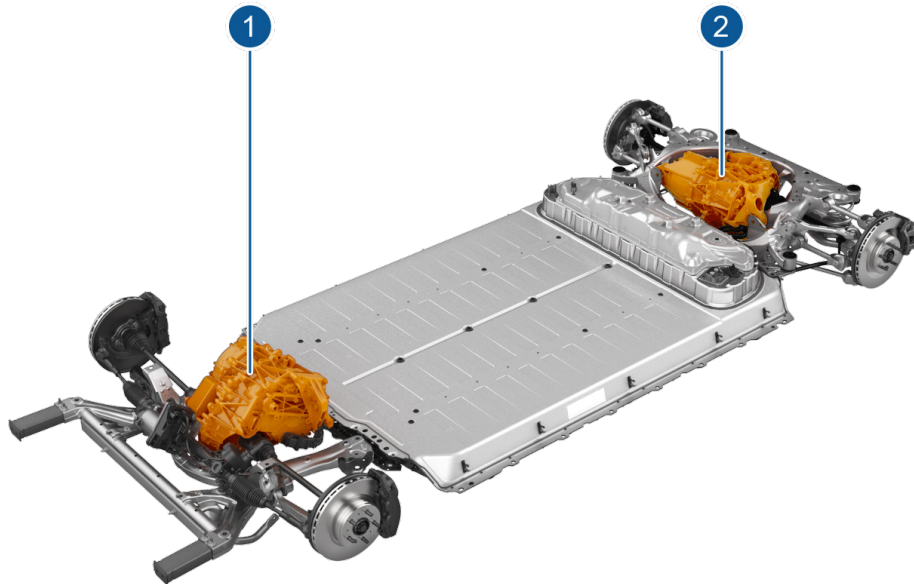

1. Front Drive Unit
2. Rear Drive Unit

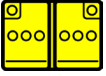

## Low Voltage Battery Pack

In addition to the high voltage system, Model Y has a low voltage electrical system. The battery of the low voltage electrical system is charged by the high voltage system. The low voltage battery operates the restraint system, seats, airbags, windows, door locks, touchscreen, and interior and exterior lights. The low voltage battery, outlined in red, is located under the hood and the plastic access panel.

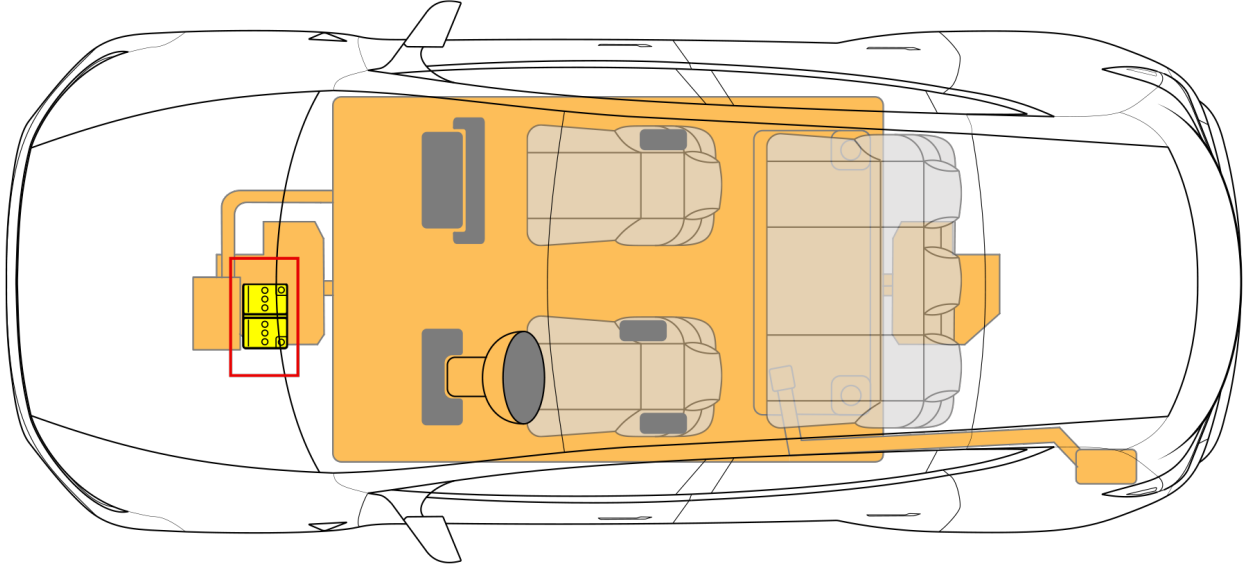

**WARNING** Cutting the low voltage battery cables doesn't always disable the low voltage system. Model Y is designed with redundancies that use the high voltage system to power the low voltage system.

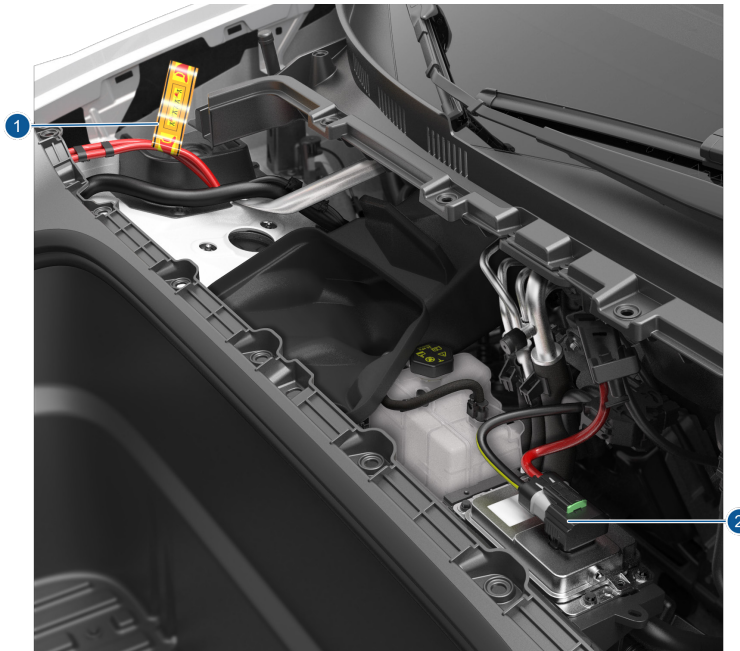

1. First Responder Cut Loop
2. Low Voltage Battery

## 6. In case of fire

### Firefighting



USE WATER TO FIGHT A HIGH VOLTAGE BATTERY FIRE. If the battery catches fire, is exposed to high heat, or is generating heat or gases, use water to cool the battery. It can take between approximately 3,000-8,000 gallons (11,356-30,283 liters) of water, applied directly to the battery, to fully extinguish and cool down a battery fire; always establish or request additional water supply early. If water is not immediately available, use CO<sub>2</sub>, dry chemicals, or another typical fire-extinguishing agent to fight the fire until water is available.

**NOTE:** Tesla does not recommend the use of foam on electric vehicles.

Apply water directly to the battery. If safety permits, lift or tilt the vehicle for more direct access to the battery (see chapter 2). Water may be applied from a safe distance **ONLY** if a natural opening (such as a vent or opening from a collision) already exists. Do not open the battery for the purpose of cooling it.

Tesla does not recommend placing the vehicle in a large container full of water. The use of a Thermal Image Camera or Infrared (TIC or IR) is recommended to monitor battery temperatures during the cooling process. Continue to use water until the battery has reached ambient temperatures or below, indicated by the thermal image camera. When utilizing a thermal image camera, allow enough time, once the application of water has stopped, to allow for heat within the battery to transfer to the battery enclosure.

Extinguish small fires that do not involve the high voltage battery using typical vehicle firefighting procedures.

During fire extinguishing, do not make contact with any high voltage components. Always use insulated tools for fire extinguishing.



Heat and flames can compromise airbag inflators, stored gas inflation cylinders, gas struts, and other components which can result in unexpected excessive heat, which can cause inflation cylinder explosion. Perform an adequate knock down before entering a hot zone.



Battery fires can take up to 24 hours to fully cool. After suppression and smoke has visibly subsided, a thermal image camera can be used to actively measure the temperature of the high voltage battery and monitor the trend of heating or cooling. There must be no fire, smoke, audible popping/hissing, or heating present in the high voltage battery for at least 45 minutes before the vehicle can be released to second responders (such as law enforcement, vehicle transporters, etc.). The battery must be completely cooled before releasing the vehicle to second responders or otherwise leaving the incident.

There is always a risk of battery re-ignition. Drain excess water out of the vehicle by tilting or raising the front of the vehicle approximately 30 cm (1 foot). This operation can assist in mitigating possible re-ignition.

Due to potential re-ignition, a Model Y that has been involved in a submersion, fire, or a collision that has compromised the high voltage battery should be stored in an open area at least 50 feet (15 m) from any exposure.



**WARNING** During all firefighting activities, consider the vehicle energized. Always wear full PPE including a Self-Contained Breathing Apparatus (SCBA).

## High-Voltage Battery — Fire Damage



Similar to conventional and other electric and hybrid vehicles, a burning battery releases super-heated gases and toxic vapors. This release may include volatile organic compounds, hydrogen gas, carbon dioxide, carbon monoxide, soot, particulates containing oxides of nickel, aluminum, lithium, copper, cobalt, and hydrogen fluoride. Responders should always protect themselves with full PPE, including a SCBA, and take appropriate measures to protect civilians downwind from the incident.



A damaged high voltage battery can create rapid heating of the battery cells. If you notice smoke, steam, or audible popping or hissing coming from the high voltage battery, assume that it is heated and take appropriate action as described above.

## 7. In case of submersion

Treat a submerged Model Y like any other submerged vehicle. The body of Model Y does not present a greater risk of shock because it is in water. However, handle any submerged vehicle while wearing the appropriate PPE for water rescue. Remove the vehicle from the water and continue normal disabling procedures as outlined in Chapter 3.

Vehicles that are waterlogged or have been submerged in water should be handled with greater caution due to the potential risk of electrical fire. After removing the vehicle from the water and completing disabling procedures, raise the front of the vehicle approximately 30 cm (1 foot) to allow water to drain out of the vehicle and the high voltage battery pack.

Submerged or waterlogged vehicles must be transported and stored more carefully. When loading the vehicle for towing, use a Thermal Image Camera or Infrared (TIC or IR) to monitor battery temperatures and check for potential hot spots and continue monitoring until the vehicle is taken away. Store the vehicle outside at a safe distance at least 50 ft/15 M from other vehicles and structures.



**WARNING** Do not use firefighting foams with vehicles that were submerged or waterlogged with salt water. The use of firefighting foams on vehicles saturated with salt water have a higher risk of electrical fire.

## 8. Towing / transportation / storage

The rear motor in the Model Y can generate power when the wheels spin. Always transport with all four tires off of the ground. Ensure that the tires are unable to spin at any time during transport.



**WARNING** NEVER TRANSPORT THE VEHICLE WITH THE TIRES IN A POSITION WHERE THEY CAN SPIN. DOING SO CAN LEAD TO SIGNIFICANT DAMAGE AND OVERHEATING. IN RARE CASES EXTREME OVERHEATING MAY CAUSE THE SURROUNDING COMPONENTS TO IGNITE.



**WARNING** POSSIBLE BATTERY RE-IGNITION! AFTER A FIRE INCIDENT, STORE OUTSIDE AT A SAFE DISTANCE (50 FT/15 M) FROM OTHER VEHICLES AND STRUCTURES!

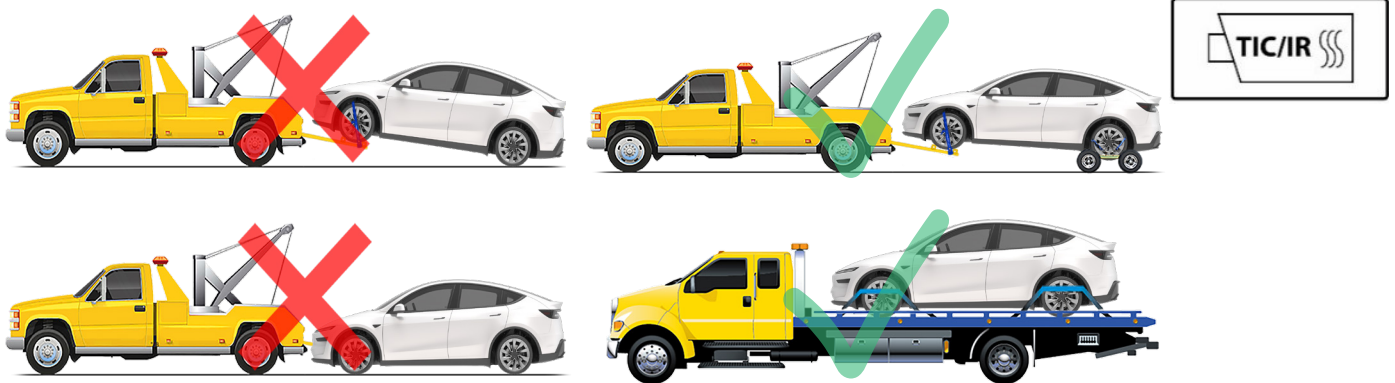

A roll-back truck or comparable transport vehicle is the recommended method of transport. The vehicle can face either direction when using a flatbed. If the vehicle must be transported without a roll-back truck, then wheel lifts and dollies must be used to ensure that all four wheels are off of the ground. This method must not exceed the manufacturer speed rating of the dollies. With this method, Tesla recommends the vehicle faces forward so that the front wheels are lifted and the rear wheels are on dollies.

**NOTE:** The tires are allowed to rotate slowly (under 3 mph or 5 km/h) and for a very short distance (less than 30 feet or 10 meters) only when Tow Mode is enabled while the vehicle is being winched onto a flatbed truck or pulled out of a parking space for repositioning. Exceeding these boundaries can lead to significant damage and overheating that is not covered by the warranty.

**NOTE:** Enable Tow Mode on the vehicle's touchscreen before winching the vehicle onto a flatbed truck. If Tow Mode is not available or the touchscreen is not accessible, self-loading dollies or tire skates must be used to load the vehicle into the approved transportation position. Tesla is not responsible for any damage caused by or during transport of the vehicle, including personal property damage or damage caused by using self-loading dollies or tire skates.



**WARNING** The vehicle is equipped with high voltage components that may be compromised as a result of a collision. Before transporting, it is important to assume these components are energized. Always follow high voltage safety precautions (wearing personal protective equipment, etc.) until emergency response professionals have evaluated the vehicle and can accurately confirm that all high voltage systems are no longer energized. Failure to do so may result in serious injury.

## Pushing the Vehicle



**WARNING** The following instructions are intended to be used when only moving Model Y a very short distance to improve traffic safety. Refer to the Owner's Manual on the touchscreen for more instructions on how to transport Model Y. Damage caused by transporting the vehicle is not covered by the warranty.



**WARNING** Pushing Model Y when it is not in Neutral or Tow Mode can result in overheating the rear motor and potential risk of shock if electrical components are exposed, even if the first responder loop has been cut.

In situations where there is minimal risk of fire or high voltage exposure (for example, the vehicle does not accelerate after coming to a stop at an intersection) and low voltage power is present, Model Y can be quickly pushed in order to clear the roadway. If a driver is present, simply shift Model Y into Neutral (N) on the touchscreen drive strip and then push the vehicle. If a driver is not present, Model Y may automatically shift into Park when it detects the driver leaving the vehicle (even if it has previously been shifted into Neutral).

To keep Model Y in Neutral (which disengages the parking brake and allows the vehicle to be pushed) without a driver present, use the touchscreen to activate Tow Mode:

1. Ensure Model Y is in Park by long pressing Park (P) on the touchscreen drive strip or the overhead console.
2. Press and hold the brake pedal, then on the touchscreen touch **Controls > Service > Towing**.
3. Touch the Enter Tow Mode button until it turns blue. Model Y is now free-rolling and can slowly be rolled (no faster than walking speed) or winched.

To cancel Tow Mode, shift Model Y into Park.

**NOTE:** Model Y must detect a key nearby and low voltage power is required for Tow Mode to activate.

**NOTE:** Tow Mode automatically cancels and the parking brake is applied if Model Y is rolled faster than 5 mph (8 km/h) or low voltage power becomes low or absent. Model Y sounds its horn if Tow Mode is about to cancel.

**NOTE:** If Model Y cannot detect the key (an authenticated smartphone or key), the Tow Mode button is grayed out and Tow Mode cannot be enabled. Call Tesla Roadside Assistance.

**NOTE:** The touchscreen is unresponsive if Model Y has no low voltage power. Use an external low voltage power supply to open the hood and jump start the vehicle's auxiliary low voltage battery. See the Owner's Manual or call Tesla Roadside Assistance for instructions.

**NOTE:** If airbags are deployed, you cannot drive Model Y. Do not push or move the vehicle unless you can enable Tow Mode. Otherwise, you must first secure the wheels for transport.

## Jump Starting the Vehicle

In situations where there is minimal risk of fire or high voltage exposure and low voltage power is not present, you can jump-start the vehicle using an external power supply. To jump start the vehicle:

1. Open the hood to access the front trunk area (see Chapter 4: Access to the Occupants).
2. Remove the maintenance panel by pulling it upwards to release the trim clips that hold it in place.
3. Pull back the black seal to reveal the jump post.
4. Remove the red cover and connect the external low voltage power supply's red positive (+) cable to the red positive (+) jump post.

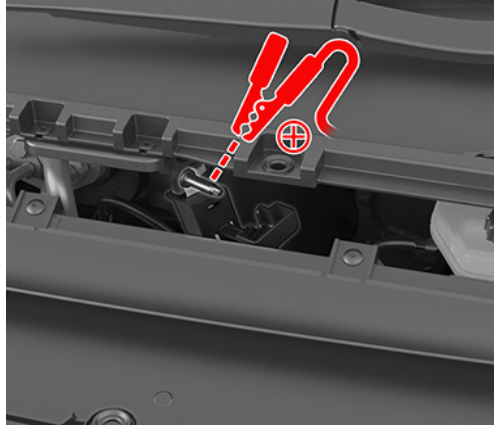

5. The HEPA filter bolt serves as the negative (-) jump post. Connect the low voltage power supply's black negative (-) cable to the black negative HEPA jump post.

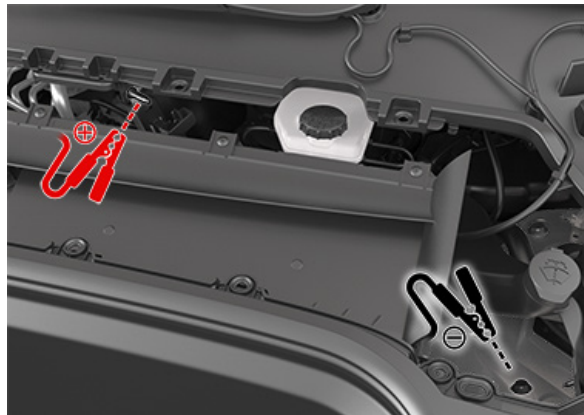

6. Turn on the external power supply (refer to the manufacturer's instructions). Touch the vehicle touch-screen to wake it up. This may take several minutes.
7. Switch off or disconnect the power supply when low voltage power is no longer needed.
8. Disconnect the cables, beginning with the black negative cable.

## 9. Important additional information

This document contains important instructions and warnings that must be followed when handling Model Y in an emergency situation.

**NOTE:** Images in this document show a Left-Hand Drive (LHD), North American vehicle. Unless otherwise noted, Right-Hand Drive (RHD) vehicles are **not** mirrored.



**WARNING** Always use appropriate rescue tools and always wear appropriate PPE. Failure to follow these instructions can result in serious injury or death.



**WARNING** Regardless of the disabling procedure you use, ALWAYS ASSUME THAT ALL HIGH VOLTAGE COMPONENTS ARE ENERGIZED! Cutting, crushing, or touching high voltage components can result in serious injury or death.



**WARNING** After deactivation, the high voltage circuit requires 2 minutes to de-energize.



**WARNING** The RCM has a backup power supply with a discharge time of approximately 10 seconds. Do not touch the RCM within 10 seconds of airbag or pre-tensioner deployment.



**WARNING** Handling a submerged vehicle without appropriate PPE for water rescue can result in serious injury or death.



**WARNING** When fire is involved, consider the entire vehicle energized. Always wear full PPE, including a SCBA.



**WARNING** When cutting the first responder loop, double cut the loop to remove an entire section. This mitigates the risk of the cut wires accidentally reconnecting.



**WARNING** When using the high voltage shut down methods recommended by this document, high voltage power is isolated to the battery. The high voltage battery is always energized.













**WARNING** Never transport the Model Y with rear wheels on the ground. Doing so can lead to significant damage and overheating. In rare cases, extreme overheating may cause the surrounding components to ignite.

### Contact Us

First Responders and Second Responders with emergencies, call Tesla Roadside Assistance. Refer to <https://www.tesla.com/support/roadside-assistance> for the applicable number.

Refer to <https://www.tesla.com/firstresponders> for the Owner's Manual and first responder information. First responders and training officers with questions, contact [firstrespondersafety@tesla.com](mailto:firstrespondersafety@tesla.com).

## 10. Explanation pictograms used

	In some working environments, the Infrared (IR) device is referred to as a Thermal Image Camera (TIC).
	Refers to the hood of a vehicle and follows with detailed procedure for opening the hood both with and without power available.
	Refers to the trunk of a vehicle and follows with detailed procedure for opening the trunk with power.
	Electricity warning
	Flammable
	Explosive
	Corrosive substances present
	Hazardous to human health
	Acute toxicity
	Contains gases under pressure
	Use water to extinguish